

DIPLOMAZIJA ASTUTA

DIPLOMAZIJA ASTUTA
MALTA PAVILION
59TH INTERNATIONAL ART EXHIBITION —
LA BIENNALE DI VENEZIA

La Biennale di Venezia

59. Esposizione
Internazionale
d'Arte

Partecipazioni Nazionali



ARTS
COUNCIL
MALTA



DIPLOMAZIJA ASTUTA

(CUNNING DIPLOMACY)

**MALTA PAVILION
AT THE 59TH INTERNATIONAL ART
EXHIBITION
OF LA BIENNALE DI VENEZIA**

**CURATED BY
KEITH SCIBERRAS AND
JEFFREY USLIP**

**ARCANGELO SASSOLINO
GIUSEPPE SCHEMBRI BONACI
BRIAN SCHEMBRI**

**PROJECT MANAGERS:
NIKKI PETRONI, LAURA DEQUAL AND
ESTHER FLURY**

COMMISSIONER: ARTS COUNCIL MALTA

CATALOGUE

PUBLISHER: Midsea Books Ltd

midseaBOOKS

COMMISSIONER: Arts Council Malta

EDITORS: Keith Sciberras and Jeffrey Uslip

EDITORIAL ASSISTANTS: Esther Flury and Nikki Petroni

CONTRIBUTORS: Albert Marshall, Keith Sciberras, Jeffrey Uslip,
Joel Marcus, Maria Cristina Terzaghi, Arcangelo Sassolino,
Giuseppe Schembri Bonaci, Brian Schembri

COPY EDITOR: Sylvia Tidwell

DESIGN AND LAYOUT: Studio Marie Lusa

PHOTOGRAPHY: Agostino Osio / Alto Piano, Massimo Penzo

In collaboration with the Department of Art and Art History,
University of Malta

2022

ISBN

Cover Image: Agostino Osio / Alto Piano



CREDITS

ARTS COUNCIL MALTA

Executive Chairman: Albert Marshall
Director Funding and Strategy: Mary Ann Cauchi
Director Corporate Affairs: Eric Fenech Sevasta
Internationalization Executive and Project Leader:
Romina Delia
Communications: Luke Cassar

MALTA PAVILION 2022

Curators

Keith Sciberras and Jeffrey Usli

Artists

Arcangelo Sassolino, Giuseppe Schembri Bonaci,
and Brian Schembri

Project Managers

Nikki Petroni (Malta), Laura Dequal (Italy) and
Esther Flury (United States)

Production Managers

Mauro Marcon
Diego Chiló

Engineers

Ermene Spagnolo
Maurizio Munari
Michele Rodighiero

Sustainability Studies Consultant

Susanna Sieff

Technical Production

Aldo Marcon
Andrea Tessarollo
Luca Tessarollo
Antonio Mocellin
Alessandro Gastaldello
Matteo Pigato
Antonio Cassano
Cristoforo Carollo
Beniamino Piotto
Andrea Bertizzolo
Valerio Chiminello
Ilario Munari
Eros Munari
Gabriele Munari
Marco Calabria
Andrea Tomasi
Manuel Fongaro
Olivo Laghetto
Pamela Randon
Guerrino Di Vietri
Stiven Gheller
Patrizio De Marchi
Cristian Battistello
Cristian Bonollo
Alessandro Maragno
Marco Borsato

Communications

Margaret House, London

Communications, Italy

Edoardo Monti
Giulia Castelli
Maria Livia Pappagallo

Graphic Identity and Publication

Sam Sciberras/Digital Creative
Silvia Dainese
Joseph Mizzi/Midsea Books Ltd
Studio Marie Lusa
Sylvia Tidwell
Massimo Penzo
Daniel Haettenschwiller/Maximage

Curatorial Assistants

Kylie Aquilina
Emma Borg
Karl Camilleri
Hannah Dowling
Elena Marcon
Giorgia Marcon
AnneMarie Saliba
Joseph Shaikewitz
Matthew Shirfield

Exhibition Assistants

Sarah Abd El Halim
Maia Borg
Amy Bugeja
Bjorn Chircop
Josmar Darmanin
Martina Darmanin
Lisa Hirth
Thea Leotta
Sarah Pisani
Michela Psaila
Sheldon Saliba
Michelle Vella Fenech

Site Officers

David Melis
Cristiano Focacci Menchini

Website Design and Development

Sam Sciberras/Digital Creative

Photography and Video Documentation

Agostino Osio, Alto Piano
Matteo Frittelli, Alto Piano
Sarah Lee Zammit
Sebio Aquilina
Desiree Attard
Clive Pace

CREDITS

SPONSORS OF THE MALTA PAVILION AT THE 59TH INTERNATIONAL ART EXHIBITION—LA BIENNALE DI VENEZIA

The Malta Pavilion was commissioned by the Arts Council Malta

The Pavilion is made possible thanks to the generous support of the following:

Lead Patrons

DMM.com
Lisa and Thomas Blumenthal
Lino Dainese
Rino Mastrotto

Patrons

Bank of Valletta
Malta Tourism Authority
IZI Group
Piero Atchugarry
Umberta Gnutti Beretta
Manuela and Carlo Bonetti
Massimo Cocco
Giuseppe Fortuna
Massimo Giammetta
Silvia Dainese Gris
Stefano Gris
Paolo Kauffmann
Sabina and Marco Rosa
Lauria and Cristian Zanussi

Additional thanks to:

Department of Art and Art History, University of Malta
TETIS Institute, Genova
Carbonsink
Fondazione Gruppo Pittini
Marcon Srl
C+Partners
Midsea Books Ltd
Valfer Spa
C.E.I.A. Spa
Telwin Spa
MTA Spa
Matherika Group
En Joy Energia
Ailis Srl
OMER Srl
Ecobeton Srl
La Barchessa di Villa Pisani by Agena Srl.
Società Dante Alighieri – Comitato di Malta

THE DIPLOMAZIJA ASTUTA CURATORIAL TEAM WOULD LIKE TO THANK THE FOLLOWING:

Andreino Albiero, Silvia Bassetto, Guido Beltramini, Jan van Biezen, Marco Bognolo, Peter Boris, Valeria Bulfoni, Paolo Chilò, Massimo Di Carlo, Giacomo Dal Prà, Dominic Fenech, Fausto Forabosco, Corban Harper, Anna Khakee, Luca Illetterati, Tiziana ed Epicarmo Invernizzi, Elsa Longhauser, Laura Lorenzoni, Kirk Miller of Miller's Oath, Son Neznakomki, Mr. Nomoto and DMM.com, Linda Norden, Gilberto Perlotto, Ikkan Sanada, Paul Sciberras, Raymond Sciberras, Samuel Sciberras, Stefano Smiderle, Paolo Tolio, Edgar Vella, Nadette Xuereb, Robert Zungu

CONTENT

- 7 FOREWORD
 Albert Marshall, Chairman Arts Council Malta
- 9 INTRODUCTION
 by Curators Keith Sciberras and Jeffrey Uslip
- 19 *WE SHALL SPEAK OF GHOST, OF FLAME,
 AND OF ASHES*
 Keith Sciberras and Jeffrey Uslip
- 29 *YOU'VE GOT TO CROSS THE LONESOME VALLEY:
 JOHN THE BAPTIST IN ART, FAITH AND HISTORY*
 Textual Sermon by Joel Marcus, Professor of New
 Testament & Christian Origins, Duke Divinity School
- 37 INTERVIEW
 between Maria Cristina Terzaghi, Associate Professor
 at the University of Rome and Malta Pavilion curators
 Keith Sciberras and Jeffrey Uslip
- 41 ARTIST SECTION I
 Arcangelo Sassolino
- 46 ARTIST SECTION II
 Giuseppe Schembri Bonaci
- 48 ARTIST SECTION III
 Brian Schembri
- 56 APPENDIX

FOREWORD

ALBERT MARSHALL
EXECUTIVE CHAIR
ARTS COUNCIL MALTA

In early 2021, Arts Council Malta—in its capacity as Pavilion Commissioner under the auspices of the Ministry for The National Heritage, The Arts and Local Government—published an international call for a curatorial team for the Malta Pavilion of the 59th International Art Exhibition—La Biennale di Venezia. A panel of judges comprising leading experts in the field selected the innovative and thought-provoking project *Diplomazija astuta* (*Cunning Diplomacy*) to represent Malta in Venice in 2022.

During the much-anticipated exhibition, curators Keith Sciberras of Malta and Jeffrey Uslip of the United States—along with artists Arcangelo Sassolino of Italy and Giuseppe Schembri Bonaci and musician Brian Schembri of Malta—re-situate the core themes of Michelangelo Merisi da Caravaggio’s seminal 1608 altarpiece, *The Beheading of Saint John the Baptist*, within the tragedies, brutalities, and injustices of modern life. The artists created a conceptual, immersive, site-specific installation that bridges a tragic biblical narrative with current social and political discourse and contemporary culture, thus reframing the zeitgeist of the Oratory of the Decollato of Saint John’s Cathedral through present-day sculptural language. Sassolino’s kinetic sculptures of molten metal and water, Schembri Bonaci’s embedded calligraphic marks and interwoven multilingual scriptural texts, and the cathartic percussive score of Brian Schembri seek to “decaravaggize” Caravaggio, specifically by propelling his *Golden Legend*–inspired canvas—in real space and time—into this century of steel, metal, and silence. This multidisciplinary work reverberates with echoes of world wars, gulags, famines, concentration camps, genocides, ecological degradation, and anthropogenic hazards.

In other words, the Malta Pavilion represents our potential future selves in the present, thereby subtly reframing the ways in which twentieth-century viewers engage with the atrocious martyrdom of Saint John the Baptist depicted in Caravaggio’s early Baroque masterpiece. Thus, *Diplomazija astuta* is a forward-looking invitation to understand ourselves, the world, and our place in it; to contemplate who we are now as a collective, who we want to be, and who we can be. It may also be construed as a complex multilayered piece of biblical exegesis, portraying the archetypal figure of Saint John as the herald of a new age of change, renewal, and continuance. Seen this way, the Maltese Pavilion becomes, poetically, a proverbial “voice in the wilderness” calling upon the artistic world at large to witness yet another advent of a new age while allowing—lest another false dawn takes hold—the Christian narrative of the Beheading to live on.

Through its engagement with Arcangelo Sassolino, one of Italy’s foremost artists, the Malta Pavilion also honors and renews the centuries-long cultural relationship between Malta and *Il bel paese*, thereby fulfilling both current *National Cultural Policy 2021* goals and Arts Council Malta’s *Strategy 2025* internationalization pledges while embracing the guiding principles enshrined in the European Commission’s cornerstone strategic document for international cultural cooperation—namely, the Joint Communication *Towards an EU Strategy for International Cultural Relations*. This also incorporates the European Union’s commitment to the UNESCO 2005 Convention for the Protection and Promotion of the Diversity of Cultural Expressions, which encourages cultural cooperation between the EU and partner countries by “promoting a global order based on peace, the rule of law, freedom of expression, mutual understanding and respect for fundamental rights.” Furthermore, *Diplomazija astuta* engages with the United Nations Sustainable Development Goals by addressing the present-day salient global challenges of poverty, inequality, climate change, environmental degradation, peace, and justice.

The chosen artistic and curatorial team is indeed the right one to represent our country in this highly acclaimed event in international contemporary art. Malta’s participation in the Venice Biennale constitutes one of the foremost international cultural exchanges of Maltese contemporary artists. Arts Council Malta is honored to have fostered the creation of *Diplomazija astuta*, an extraordinary contemporary artwork with a challenging message for our time.

INTRODUCTION BY CURATORS

KEITH SCIBERRAS AND
JEFFREY USLIP

The Maltese Pavilion, titled *Diplomazija astuta (Cunning Diplomacy)*, reimagines Caravaggio's seminal altarpiece *The Beheading of Saint John the Baptist* (1608) as an immersive, site-responsive installation that overlays biblical narrative onto the present and the noetic onto the metaphysical. The collaborative effort of curators Keith Sciberras and Jeffrey Uslip, artists Arcangelo Sassolino and Giuseppe Schembri Bonaci, and composer Brian Schembri layers *that which is said to have passed with that which is still unfolding*, creating a palimpsest that uniquely operates within the realms of Caravaggio's altarpiece and contemporary visual culture.

By transposing the zeitgeist of the Oratory of the Decollato in Valletta, where *The Beheading* is situated, onto the Malta Pavilion, the curatorial team transports spectators into the compositional and thematic space of the painting, elevating the potential for art to lead us forward through our complex moment in time and offering the work as both an urgent forewarning and a conduit into the parallel and overlapping histories of Malta and Italy. *Diplomazija astuta* re-situates Caravaggio's immanent themes within modern life, prompting viewers to navigate a space where the tragedy and brutality of Saint John's execution is experienced in the present; the injustices of the past (and present) are reconciled; and shared humanist principles can be upheld in the future. The curatorial team posits that we are back in the time of John. For society to embody its future self in the present, the signal material of Modernism—*steel*—must be physically, metaphorically, and spiritually melted to create space for progress to occur.

Arcangelo Sassolino's kinetic installation is anchored by a monumental, freestanding solid steel plate, weighing sixteen tons and measuring 360 × 520 cm—the exact dimensions of Caravaggio's canvas—at one archway of the pavilion. As an austere industrial surrogate, the metal plane serves as a physical analog to Caravaggio's painting, creating a doubling across time and space as it recalls how viewers have experienced *The Beheading* in Malta since the early seventeenth century.

Positioned throughout the exhibition space are seven water-filled square steel basins that echo the arrangement of the seven figures in Caravaggio's composition. Emulating the pictorial environment of *The Beheading*, the reservoirs represent the figures in the painting: John the Baptist, the executioner, Salome, her assistant, the jailer, and two prisoners. Situated above each pool is a computer-programmed system that feeds coils of steel into an induction machine whose electromagnetic field almost instantaneously melts the metal at 1500 degrees Celsius, conjuring droplets of molten steel to fall from the ceiling into the basin of water below. Upon contact with the water, the bright orange embers hiss, cool, and recede into darkness.

Taken as a whole, Sassolino’s immersive, visceral environment confers biblical import on induction technology, imbuing the pavilion with an uncanny yet modern familiarity. We have walked into a contemporary experience of the Oratory of the Decollato, as well as into a twenty-first-century iteration of Caravaggio’s picture plane, *in medias res*. For Sassolino, *Diplomazija astuta* liberates metal from its solid form, revealing the potential of its liquid state. The molten steel embodies “living” time, expanding and radiating light at exceedingly high temperatures . . . until the light is reclaimed by darkness. *Diplomazija astuta* allegorizes the continuous cycle of agency and loss, the impossible and unstoppable flow of events—symbolized by evanescent intervals in which light is carved out of darkness.

On its other axis, the steel plate reveals Giuseppe Schembri Bonaci’s *Metal and Silence*, a multilingual incision of text that weaves Aramaic, Hebrew, Latin, and Greek—together with those languages that compose the Maltese linguistic structure (Italian, Arabic, and English)—into the form of the artist’s cardiac sinus rhythm. Schembri Bonaci culls texts from Ezekiel 37 and Psalm 139 to presence the creation of humankind as a universal act. The words and letters incorporate multiple primordial spellings, incantations, and meanings: *osse, ossa, ossea*; form, *forma, μορφή*; humankind, *hominum, homine*; life, *vita, anima*; God, *Dio, Alla, Allah*. *Metal and Silence* conveys Schembri Bonaci’s position on materiality and its *faktura* counterpoint, art, biblical narrative, politics, ideology, language, and life itself across diverse eras in human history: the birth of Logos from the scratched, scorched surface of the earth.

With a nod to the formal and conceptual structures of the Pillars of Melqart and the Rosetta Stone, *Metal and Silence* allows viewers to experience the struggle between words, silence, letters, and pauses. Schembri Bonaci’s incisions into the installation itself—forming a sculpted ciphertext—propose a daunting salve that embeds knowledge beyond and within our grasp.

The composer for this project, Brian Schembri, interacts with the machine’s output—falling fire—through a set of musical organizing principles. Schembri based his engagement with *Diplomazija astuta* on a number of musical works or their elements, including “Ut queant laxis,” the Gregorian chant attributed to Guido d’Arezzo in honor of John the Baptist; rhythmical motifs derived from Carlo Diacono’s two hymns composed on the same Latin text; and Charles Camilleri’s *Missa Mundi*. Guiding the timing and frequency of each descending ember and ordering the sequence in which the machines operate, Schembri challenges the installation to reinterpret his percussive score in aleatoric dialogue among itself, its various components, and the original composition.

With the principles of the United Nations Sustainable Development Goals on climate change, environmental protection, peace, and justice in mind, the environmental consulting team for *Diplomazija astuta* calculated the total CO₂ produced by the installation, in order to reduce it and then to offset it with the help of Carbonsink. It is the first sculpture that the international certification

body DNV has recognized as carbon neutral, certifying the installation as environmentally conscious and ethically sound.

Through the shared vision of the artists and the curatorial imprint of Sciberras and Usliip, *Diplomazija astuta* presents a new social contract: viewers encounter a transcendent and immersive installation in which global challenges can be seen with fresh eyes and injustices can begin to be reconciled. Through the re-presentation of Saint John's beheading in a contemporary sculptural language, biblical tragedy resonates with current world events, revealing the blind spots, miscues, and failures of the humanist project across millennia: deceit, culture copying, virtue signaling, media malpractice, and the weaponization of ideas.



Caravaggio, *The Beheading of St John the Baptist*, 1608, Oil on canvas, 360 × 520 cm, Oratory of St John the Baptist, St John's Co-Cathedral, Valletta, Courtesy of Foundation for St John's Co-Cathedral.





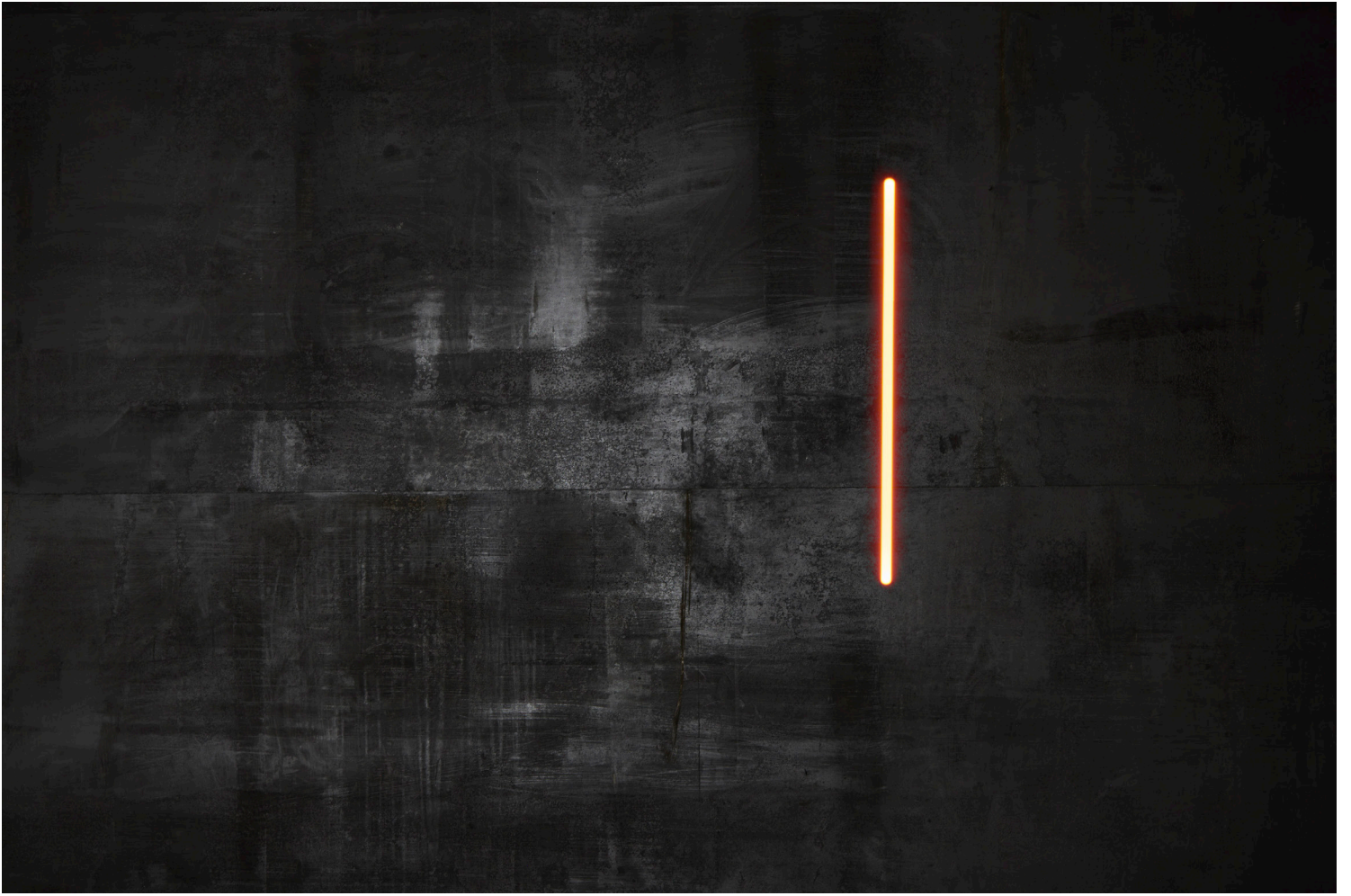









WE SHALL SPEAK OF GHOST, OF FLAME, AND OF ASHES

KEITH SCIBERRAS AND
JEFFREY USLIP

Individuals are beheaded for myriad reasons—namely, when their ideas, personas, and truths challenge, disturb, and threaten the mediocrity of the status quo. While the fate of John the Baptist is a cautionary tale, it provides a cipher to decrypt and unmask the complex pretexts of our weaponized time. John is believed to have possessed two signal truths: he anticipated the arrival of a new Messiah, Jesus, and he understood that King Herod Antipas’s second marriage to Herodias was illegitimate when he married his half-brother’s ex-wife. On its face, either of these assertions had the potential to upend the political and social hierarchy of the time; however, in tandem, John’s knowledge was exponentially more dangerous, and therefore his existence was deemed too dangerous to leave unattended. Subsequently, Herodias crafted the infamous plan in which her daughter Salome would dance the famed “Dance of the Seven Veils” in exchange for John the Baptist’s head, resulting in the prophet’s arrest, execution, and future sainthood.

Caravaggio, like John the Baptist, was a polarizing figure whose truths upended political covenants and challenged social norms, and whose eventual execution culminated in aesthetic martyrdom. In 1607 the painter left Naples for Valletta on a galley of the Order of Saint John of Jerusalem, seeking support from the Knights of Malta for his eventual pardon from papal authorities after committing murder in Rome. A year after his arrival in Malta, Caravaggio was inducted into the Knights of Saint John and completed the seminal altarpiece *The Beheading of Saint John the Baptist*—a work that resides today both at the conceptual center of the Malta Pavilion and at the core of Western art history.

When Caravaggio entered the Conventual Church in Valletta for the first time in July 1607, he would have noticed, beyond the first bay on the right, a large portal leading into a long hall that was nearing completion. Built between 1602 and 1607, this was the Oratory of the Decollato, where the knights held occasional ceremonies and where the *Confraternità della Misericordia*—the “Brotherhood of Mercy”—so powerful and influential at the dawn of the seventeenth century, congregated. The hall was high and bare, with blank walls that defined its plain, box-like geometry. This space was to become the setting for Caravaggio’s masterpiece.

Caravaggio’s Maltese story reached its climax with the completion of *The Beheading of Saint John the Baptist*, which he likely executed between March and July 1608. *The Beheading* is Caravaggio’s largest painting and certainly one of the grandest of his oeuvre. Signed in his own “blood”—the same color that he used

to depict the blood issuing from John's wound—this painting makes a harrowing biographical statement and simultaneously captures, with a damning realism, the final moments of the Order of Saint John's patron and protector. Through this picture, the Oratory of the Decollato celebrated the martyr's blood and, thus, also celebrated the blood of Christ, called the greatest of all martyrs.

The artist, instructed to paint the subject of John's beheading, evidently reflected carefully on the rectangular space of the oratory, dramatically dominating the architecture by setting the artwork at the end wall. The great, horizontally laid painting, whose surface was stitched together from four bands of canvas, spread over five meters in width. The imposing size reflects Caravaggio's desire to impress the grand master and his council, perhaps after he promised to make *The Beheading* his largest work and to fill the entire space of the oratory's end wall. Additionally, because altar paintings were normally vertical in format, the choice of a vast horizontal composition was both impressive and new to the island.¹

The Beheading depicts the very moment of Saint John's execution, as he and the other figures populate a shallow, stagelike pictorial space that appears to extend into the viewer's own physical space. For this project, the artist moved beyond the spatial models and compositional structures he had habitually used for his earlier large works in both Rome and Naples. By taking into account the spectator's viewpoint (especially during prayer and the mass) and then calculating the work's design and placement with mathematical precision, Caravaggio ensured that the artwork's fateful scene would be "performed" directly in front of viewers and be perceived almost as if it were actually taking place in the Conventual Church itself. Through the artist's agency, then, the audience within the oratory becomes silent witness to John's horrific death.

It is pertinent that, among its relics, the Order of Saint John possessed the hand of Saint John—its most precious relic—and was responsible for its preservation. On feast days and other special occasions, it was displayed on the upper gradine of the altar in the Oratory of the Decollato. The painting's vivid image of John's spilled blood in proximity to the holy relic must have had a powerful spiritual impact on the faithful in attendance.

Beyond his attention to the spatial relationship between the artwork's scene and the surrounding church interior, Caravaggio exhibits a masterful arrangement of pictorial space and complete control of the gestures and actions in this brutal scene. A cerebral composition rendered with extraordinary realism, it is, at the same time, the most classically composed work of his career. A perfect arch, shifted to the left side of the picture plane, groups the characters symmetrically, while

¹ The Knights' reception of this picture was ecstatic, and it provided the political justification and social capital for Caravaggio's elevation to knighthood. The oration for the artist's knighthood ceremony, probably written as a reaction to the painting, was surely composed while *The Beheading's* paint was still wet. The glowing response is reflected in the oration: "Should we [the Knights of Saint John] compare him [Caravaggio] to more recent artists of our age, we may not afterwards be envious of the artistic excellence of some other man, outstanding in his art, whose name and brush are equally important." The painting was probably started in spring 1608, after Caravaggio received news of the papal dispensation for knighthood; it was surely completed, or at least signed, after July 14 of that year.

the figures of John and his executioner are placed directly in the center of the work. With the oratory's main door open, the saint—slain and thrown onto the ground—could be seen directly on the axis from the main nave of the Conventual Church. This is clearly no coincidence, and Caravaggio must have taken this into account as he conceived the work, most probably pacing to and fro on this axis. The spatial setting of the oratory and its relationship to the main body of the Conventual Church figured heavily in the manner in which Caravaggio laid out his composition and decided where to place its focal point.

The stately and somber composition is fundamentally dark. It is illuminated only by light entering from the upper right, isolating and focusing strongly on the blood. This light's presence increases the resonance of the act and underscores the classical perfection with which Caravaggio arranged the figures. The calculated position of each of the figures—and their expressions, movements, and gestures—exemplify Caravaggio's new method of presenting a narrative of human feelings and passion within grand spatial constructions.

The painting's narrative is set within the grand geometric space of a Maltese courtyard. Stripped to its bare essentials, it breaks the eerie silence pervading the scene. Five protagonists are placed in a closely knit, arched group on the frontal plane. The Baptist is on the ground; the executioner, holds him firmly while he trades his knife for the sword; the master of the jails indicates where the severed head should be placed; a maiden (it is not clear if she is Salome) leans over with the platter in her hands; and an old woman expresses her horror at the bloodbath by clutching her head in anguish. On the right side in the background, shown within the confines of the prison, two convicts watch the grisly scene intently. Caravaggio depicted the group around the Baptist—namely, the maiden, the old woman, and the jailer—in contemporary dress, continuing a practice that he had already made use of for his altar paintings in Rome.

The Beheading of Saint John the Baptist is stark, direct, and intense. In a manner that marked his entire career, Caravaggio broke through tradition, anchoring the visual and emotional image in reality, and he challenged firmly set typologies. This work's narrative is devoid of iconographic elements. No angel, no halo, no palm frond—none of the established symbols of martyrological victory are shown; instead, the emphasis is on the proximity of death and on heroic suffering. Seconds into his execution, the Baptist does not react, though he is moments away from his last breath. His eyes are closed, and the artist has imbued his prostrate body with a dramatic spiritual energy.

The head of John is not placed on a martyr's plinth; instead, his body is pictured face down on the ground while he is being cold-bloodedly executed like a sacrificial lamb. The martyr's head is at rest, his eyes are closed, and the serenity of his expression gives the impression that this is the most charitable of deaths. Caravaggio focuses on the blood—the blood that has started to spread and pool on the ground, marking the precise location where the action is unfolding. The

artist placed this event at the exact center of the composition, very low in the pictorial space and in the foremost frontal plane. For the viewers seated within the oratory, it seems almost as if John has been placed on the altar gradine, and his blood is about to spill down upon it.

Caravaggio's *Beheading* also embodied the manner in which the Council of Trent had promoted the portrayal of Christian martyrs. In its engaging realism and its naturalistic representation of physical corporeality, Caravaggio brilliantly summed up the Counter-Reformation spirit through which scenes of martyrdom brought Christians face to face with death, so that they might learn to not fear it. The act of dying for the religion epitomized the knightly ideal of resurrection with Christ. Consequently, episodes of self-sacrifice or stoic virtue and, especially, of shedding one's blood for the religion had long been glorified by the Church's historians. This approach tallied with the Order's own agenda with regard to the immortalization of suffering and martyrdom. It is significant that the Oratory of the Decollato itself would be used by the Knights of Saint John for the instruction of their novices.

The enormous success of *The Beheading* set the stage for Caravaggio's most prestigious social achievement in Malta—his new status as a knight. Significantly, he signed the work «*f. Michelang ...*» in the same paint he used to depict the blood flowing from the Baptist's slit throat. In this instance, the *f* did not stand for *fecit* (Latin, "he made" [this work]), which was customary, but for *frater*, or brother, and reflected the artist's new investiture as a Knight of Saint John. This act poignantly ties in with his intention to show his readiness to mark himself with the martyr's blood, if there were ever the need for it. The choice of displaying his signature so visibly reflects his gratification at having achieved the honor of knighthood. The signature also sealed his mark on a painting made primarily as an expression of virtue. Placed precisely at center, along the lower perimeter, the signature proudly declared that Michelangelo, Knight of Malta, had created this work. Never before had Caravaggio signed any of his works, but this painting and its context were different: this signature was not about his artistry or his revolutionary style. Instead, it was the signature of a knight—specifically, of a man who, through consummate virtuosity, had redeemed himself, had regained his social status, and was paving the way for his eventual return to the papal city.

The Beheading of Saint John the Baptist is now understood as a pivotal work in Caravaggio's career, one that heralded a decisive shift in his oeuvre. Development in the artist's technical practice defines the manner in which Caravaggio was to execute his large final works.

The informant in Malta of Giovanni Pietro Bellori, an early biographer of Caravaggio, was impressed by the artist's liberty of execution and the strength and power of his brushwork. Caravaggio's brush hit the canvas with bold rapidity and dexterity on a monumental scale. He reported that, in the vast space of the background, the artist allowed the reddish brown ground to seep through as a

middle tone and, in other areas, played with forceful highlights to model his figures with simple and direct strokes.

The context of street life within a Neapolitan alley that Caravaggio had given to *Seven Acts of Mercy* was abandoned in favor of a geometric conception of vast space. This expansive space and *The Beheading's* bold compositional model paved the way for his Sicilian pictures—namely, *Burial of Saint Lucy* and *The Raising of Lazarus*. The Sicilian pictures possess the same technical character and application of pigment. Based on technical considerations, *The Beheading* is, therefore, a milestone picture that best signifies the change in working method that the artist adopted in Malta and that he employed in his brief yet dramatic period of activity thereafter.

The martyrdom of Saint John the Baptist, with his transfer from the prisons to his execution, provided the perfect subject for both the Knights of the Order of Saint John and the *Confraternità della Misericordia*, which had oversight of the Oratory of the Decollato. In his painting, Caravaggio responded fully to the Confraternity's official purview over the saving of souls. The two prisoners looking at the martyrdom scene were witnessing the saint's supreme and noble act of "dying well."

* * * * *

In our current complex and challenging times, art empowers us to discern our collective past and offers clues for being our future selves in the present; visual culture presents us with imagery, objects, environments, and installations that enable us to understand who we *were* and who we *can be* in the future. Art holds a mirror to our current imaginary and offers an opportunity to face the past and collectively reach a new humanist contract. *Diplomazija astuta* responds to our current crossroads and cultural imaginary—elevating the potential for art to lead us forward, yet only through a direct reconciliation with the past, from the genesis of biblical thought. By re-situating Caravaggio's immanent themes within modern life, *Diplomazija astuta* prompts viewers to navigate a space where the tragedy and brutality of Saint John's execution is experienced in the present, injustices of the past are reconciled, and shared humanist principles can be upheld in the future.

Diplomazija astuta posits we are back in the time of John, and, for society to embody its future self in the present, the signal material of Modernism—*steel*—must be physically, metaphorically, and spiritually melted to create space for progress to occur. Modernism forged progress (in steel)—it created the world in which we live; however the skirr of Modernism's industrial progress came with a price: it showed us that humankind was capable of destroying itself (the advent of carbon polluting technologies, the construction of racist highways, and the creation of the atomic bomb as examples). In order for societies to catalyze progress, in order to be our future selves in the present, we must literally, metaphorically,

and spiritually melt the material of Modernism (steel) to create space for new progress to occur. We must create the Future's future.

Diplomazija astuta transforms the Malta Pavilion into the physical, spiritual, and emotional space of Caravaggio's painting to tackle the many of global challenges we face in today's world, including inequality, justice, and peace. Through the representation of Saint John's beheading through a contemporary sculptural language, biblical tragedy resonates with current world cultural events and offers viewers a visceral examination of justice and peace. In turn, *Diplomazija astuta* overlays the first century A.D. onto the twenty-first, flattening time and presenting a transcendent cultural experience where beholders imagine a path toward reconciliation.

Arcangelo Sassolino echoes the absorptive qualities and thematic overtones of Caravaggio's canvas by unfolding the altarpiece into the space of the Malta Pavilion and into the realm of contemporary social and political discourse. Sassolino's kinetic installation conjures *The Beheading of Saint John the Baptist* by first anchoring a monumental, freestanding, 150 ton stainless steel plate measuring 370 x 520 cm—the exact dimensions of Caravaggio's canvas—at one archway of the pavilion. Curatorially, this intervention creates a physical analogue to the location of Caravaggio's painting at the Oratory of the Decollato in Valletta and recalling how viewers have experienced *The Beheading* in Malta since the early seventeenth century. As an industrial and austere surrogate, Sassolino's metal plane transports the altarpiece's presence and imposing scale to the Venice Biennale, creating a doubling across time and space, in both two and three dimensions.

Situated in front of Sassolino's freestanding steel plate are a series of seven black stainless steel, rectangular basins that echo the arrangement of the seven figures in Caravaggio's composition and emulate the pictorial environment of *The Beheading*. Each reservoir represents one of the figures in Caravaggio's *The Beheading*: John the Baptist himself, the executioner, Salome, her assistant, the jailer, and two prisoners. Minimalist in form, the seven identical basins hold shallow reflecting pools of water, each a metaphor for the aqueous unconscious. Located above pool, and hidden along scaffolding overhead, are seven computer-programmed devices that feed coils of 5 mm steel into individual induction machines through the use of a computer program. As each steel coil is shepherded through the induction machine, an electromagnetic field almost instantaneously melts the metal, forcing molten droplets to fall from the ceiling. Upon contact with the water, the bright orange embers hiss, cool, and recede into darkness. The flashing embers, like fire raining down from celestial space, or perhaps blood falling from the sky, animate a common religious motif for judgment.

Taken as a whole, the scale and physical location of Sassolino's steel plate, coupled by the Malta Pavilion's spiritual resonance and arched thresholds, recalls the pictorial environment of *The Beheading*. Sassolino's immersive, visceral environment applies biblical import to induction technology, imbuing the pavilion with an uncanny, yet modern, familiarity: we have walked into a modern experience of the Oratory of

the Decollato and a twenty-first-century iteration of Caravaggio's picture plane: a lived "in medias res." *Diplomazija astuta*, as in Sassolino's entire corpus, "embraces the visceral tension between fascination and anxiety by creating machines whose actions intrigue the viewer and likewise pose an immediate and tangible threat."²

Sassolino's exploration of Caravaggio and Maltese history through molten steel and water, violence and calm, represents a defining moment in the artist's career. Throughout his oeuvre, Sassolino experiments with industrial, mechanical, and alchemical maneuvers to comment on the experiences and trials of human life "creat[ing] a moment that is imminent, urgent and captivating [. . . pushing] the spectator's psyche into a strange and uncomfortable place—one that is cognizant and wary of the deconstructive actions about to take place yet fully absorbed by the sculpture's aesthetic capacity."³ This keen awareness of spectatorship transforms the viewing experience into an acute encounter with oneself and one's relationship to the material and metaphysical world. Over the past three decades, Sassolino's signature visual language "simultaneously updates and razes the tenets of both Minimalism and Post-Minimalism—including factory fabrication, the elimination of the artist's hand, seriality, the implementation of autobiographical and sensuous materials, and the exploration of weight and gravity—to allegorize the brutality of bare life."⁴

The steel plate's verso reveals Giuseppe Schembri Bonaci's *Metall u skiet / Metal and Silence*, a multilinguistic textual incision that weaves Aramaic, Hebrew, Latin, Greek, Arabic, together with those languages that compose the Maltese linguistic structure; Italian, Arabic, as well as English, into the form of the artist's cardiac sinus rhythm. Schembri Bonaci culls texts from Ezekiel 37 and Psalm 139, to provide sculptural form to language, make the spiritual concrete and reflect the creation of humankind as a universal act of a work of art. The depicted words and letters reflect multiple primordial spellings, incantations, and meanings: *osse, ossa, ossea*; form, *forma, μορφή*; humankind, *hominum, homine*; life, *vita, anima*; God, *Dio, Alla, Allah*. *Metal and Silence* conveys Schembri Bonaci's position on materiality and its *faktura* counterpoint, art, biblical narrative, politics, ideology, language, and life itself across diverse eras in human history: the birth of *Logos* from the scratched scorched surface of the earth. With a nod to the formal and conceptual structures of the Melqart pillars and the Rosetta stone, *Metal and Silence* syncretize the struggles between words, silence, letters, and pauses—creating a "multi-layered relationship existing at different historical moments."⁵ Schembri Bonaci's incisions into the installation itself (a sculpted ciphertext) propose a daunting salve that embeds knowledge beyond and within our grasp.

2 Jeffrey Uslip, "Bare Life; Or, What Lies Ahead," in *Arcangelo Sassolino: Fragilissimo* (Verona: Edizioni Galleria dello Scudo, 2020), 74–75.

3 Uslip, "Bare Life," 74.

4 Uslip, "Bare Life," 74.

5 Giuseppe Schembri Bonaci, *Metal and Silence: The Quest for Daringness and Authenticity in the Arts* (Valletta: Horizons, 2019), 21.

For Schembri Bonaci, language moves across space and time, recorded in a multitude of languages, universalizing our shared experiences and revealing how our subjectivities are initially incomprehensible to one another; yet over time, language can encourage the body politic to cohere. Schembri Bonaci's embedded calligraphic marks and interwoven texts manifests an *élan vital*—languages striving for clarity, struggling to un-conceal the concealed truth. Here, spirituality is the manifestation of existential considerations that build a sustainable and just world, focusing our collective lens on the *common heritage of mankind* rather than its differences. Schembri Bonaci's intervention broadens the space of religion to the multicultural and embodies physicalized scripture, a “manifestation through incisions, slashes, and cracks,” and calls for silence, listening, literacy and, in turn, healing.⁶

Understood in the context of Malta's past and present, *Diplomazija astuta* engages viewers in the continuities of humankind. At the same time, the installation calls forth a broader re-examination of history from the vantage point of the Italian peninsula and within Malta itself. The artists' use and interrogation of metal draws relation to the material and political histories of the twentieth century, which ushered in the era of steel and metal. For each artist, metal is an indicator of progress and modernity, which, over a century, transformed the sustainability of the planet as a whole into a dangerous apocalyptic 'zone.' The significance of metal—steel—in the First and Second World Wars—its use in weaponry and steel-clad tanks, missile production and naval fleets—associated the ore with its capacity for violence and geopolitical transformation. Steel denotes our modern age: it has defined the century of wars, skyscrapers, military weaponry, and transportation. Industrialization furthered Malta's own position at the center of the Mediterranean and importance as a military fortress prior to its neutrality status, creating a renewed place for metal within the national consciousness. In *Diplomazija astuta*, steel—the material intrinsic to twentieth-century modernity and impending doom—is melted to allegorically and biblically usher in twenty-first-century progress, healing, reconciliation, and, by extension, justice and peace.

Diplomazija astuta and *Metall u skiet / Metallo e silenzio* deliberately juxtapose this metallic-ization of human history with the biblical era to address all multicultural, inter-religious, and non-religious approaches to existential choices humankind is now facing around political, social, and cultural sustainabilities. This dilemma is one Malta had already reacted to in the late 1960s, when proposing a “common heritage of mankind” on the international stage, putting forth a legal norm to empower collective progress and move away from individualistic exploitation.⁷ As we live through an era where justice and humanity are tested to their greatest extremes, Sassolino and Schembri Bonaci's work—like John the Baptist himself—

6 Schembri Bonaci, *Metal and Silence*, 182.

7 Giuseppe Schembri Bonaci, “Not Art Only: The Common Heritage of Mankind as an Alternative Road to Paradise,” in *The APS Mdina Cathedral Contemporary Art Biennale 2020: Regaining a Paradise Lost: The Role of the Arts*, edited by Giuseppe Schembri Bonaci and Nikki Petroni (Valletta: Horizons, 2020), 69–87.

re-present a cautionary tale, a moment to stop in one's tracks and become present to the real stakes of justice and peace.

The composer for this project, Brian Schembri interacts with the machine's output—falling fire—through a set of musical organizing principles. Schembri's contribution to *Diplomazija astuta* was inspired by a number of works, including a medieval interpretation of a sapphic strophe (as edited by Gregorian chant specialist Dr. Jan van Biezen) extracted from “Ut queant laxis,” a Gregorian chant hymn honoring John the Baptist, attributed to music theorist Guido d'Arezzo (c. 991–after 1033), who first devised the names of the seven notes of a scale by basing them on the first syllable of each strophe of this hymn, conceptually echoing the seven figures in Caravaggio's *Beheading*; and rhythmical motifs derived from Carlo Diacono's two hymns composed on the same Latin text; and twentieth-century Maltese composer Charles Camilleri's (1931–2009) *Missa Mundi*— Fire over the earth, Fire in the earth, and Communion. Guiding the timing and frequency of each descending ember and ordering the sequence in which the machines operate, Schembri challenges the installation to reinterpret his percussive score in aleatoric dialogue between itself, its various components, and the original composition, each interacting with the twentieth-century thought and aesthetics, all centered around Saint John's saga. The installation's raining fire and conceptually rigorous intent take viewers on an experiential journey.

Diplomazija astuta turns the Malta Pavilion into a spiritual space in which the audience is asked to immerse itself into the aura of *The Beheading*, to engage with metal and silence, with fire as it is engulfed by water. Sassolino's intervention invites audiences deeply into the heart of the work, capturing the delicate balance between emotive intensity and austere stillness. For instance, the red-hot embers evoking the depicted blood of Saint John—from which Caravaggio signed his own name, for the first and only time in his life—flash before visitors in a bright blaze, refocusing them on the *here* and *now* of the sculptural environment. Each fiery spark, plummeting down from the celestial to the earthly, marks the injustice of Saint John's execution and calls forth the capricious, selfish, decadent devices of power, otherwise known as *diplomazija astuta*, or “cunning diplomacy.” And yet, as soon as the embers—sparks that might light a fire of justice—appear, they are engulfed by the pools of standing water, creating a momentary stillness and a quietude in which visitors can contemplate cycles of violence and their consequence. As time lapses and the room is filled with passages of both intensity and silence, the possibilities for justice and transformation move in and out of the viewer's realm of understanding. As visitors to the Pavilion encounter this panorama of molten downpour, the hissing pools of water, and the commanding metal proxy before which this scene comes to life, Caravaggio's vision of a biblical event transforms into a present-day allegory of cruelty and vengeance. And yet, through Sassolino's rigorous and at times terrifying manifestations of kinetic, sculptural presences, *Diplomazija astuta* asserts “the oppositional notions of doubt

and faith: doubt and faith in our capacity as a polis to rebuild and support the citizenry; doubt and faith in local, state and federal governance; doubt and faith in the ‘truth-value’ of our positions.”⁸ *Diplomazija astuta*’s agency and potential for causing change is therefore haunted by the specters of John’s beheading (its signal causes and consequences), competing political agendas, cultural mores, social realities, and instrumentalized geopolitics.

While grounded in both the biblical past and our collective present, Malta’s history alongside that of Italy, *Diplomazija astuta* encourages the tragedies of human existence to transcend time and offer a reflective path toward justice, reconciliation, and peace. *Diplomazija astuta* demonstrates how sculpture can represent society’s ideologies and ideals by envisioning an environment in which spectators are embedded within the event of Saint John’s beheading and its allegorical currency. In turn, visitors to the Pavilion assume multiple positions at once: witnesses to a moment in biblical history, the onlookers depicted in Caravaggio’s painting, viewers of the altarpiece *in situ*, and inhabitants of the events *in medias res*—as its narrative unfolds. The artists produce an engrossing space through which one must confront this symbolic tragedy through one’s own body. The artists *refigure* Caravaggio’s *The Beheading* in a twenty-first-century context, refining it to sheer mass and space, re-signifying its iconography to capture and preserve its striking essence.

From this visceral experience of the unrighteous and the unjust, the tragedies of the present and their global scale come to be understood anew. Through *Diplomazija astuta*, a new social contract can be reached: viewers will encounter a transcendent and immersive installation in which global challenges can be seen with fresh eyes, the injustices of the past can begin to be reconciled, and we can hold our future selves to the current moment through shared humanist principles. Through the re-presentation of Saint John’s beheading in a contemporary sculptural language, biblical tragedy resonates with current world events, revealing the blind spots, miscues and failures of the humanist project across millennia: deceit, virtue signaling, media malpractice and the weaponization of ideas.

⁸ Jeffrey Uslip, “Bare Life; Or, What Lies Ahead,” in *Arcangelo Sassolino: Fragillissimo* (Verona: Edizioni Galleria dello Scudo, 2020), 75.

LONESOME VALLEY: JOHN THE BAPTIST IN ART, HISTORY, AND FAITH

JOEL MARCUS

Like some visitors to this exhibition, I first encountered John the Baptist in a work of art—the American spiritual “Lonesome Valley.” Not having grown up in the church—being from a secular American Jewish family—I had heard John’s name mentioned once or twice by Christian friends, and I had somehow picked up the salient fact (relevant to this exhibition) that he had ended up losing his head. But beyond that, John the Baptist was a blank to me except for “Lonesome Valley.”

That was the sign-off song for “The Midnight Special,” a program on the radio station my family listened to, WFMT in Chicago. This was a classical music station—in the 1950s, the only one in town—but “The Midnight Special” was, as the announcer said each Saturday night, “our weekly aberration—a program of folk music and farce, show tunes, satire, and odds and ends.” (This introduction, like the program itself, had been created in 1953 by a young announcer named Mike Nichols, who went on to even greater things.) The program always began with Huddy Leadbetter (better known as Leadbelly) singing his famous prison song “The Midnight Special,” and it ended with Richard Dyer-Bennet, the British-born tenor, singing a version of “Lonesome Valley.” It starts with this haunting refrain:

You’ve got to cross that lonesome valley
You’ve got to cross it by yourself
There ain’t no one can cross it for you
You’ve got to cross it by yourself

The first verse introduces the theme of crossing “Jordan River”:

Jordan River is chilly
Jordan River is cold
Jordan River is wide and deep
But you can’t drown a good man’s soul

This theme was familiar from the popular folk song “Michael Row the Boat Ashore,” which seemed to be sung at every hootenanny I ever attended. But the second verse was unlike anything I had encountered in folk song, spiritual, poem, or anywhere else:

Some say John was a Christian
 Some say John was a Jew
 But I say John was a natural man
 And he was a preacher too

I made the connection between this John and the person whom my Christian friends called “the Baptist.” But I puzzled over the question of how it could be uncertain whether this “John the Baptist” was a Christian or a Jew. In our Chicago suburb, you were either one or the other; there was usually no ambiguity. Had things been different in ancient Palestine? And what did it mean that John was *neither* a Jew *nor* a Christian but a “natural man”?

I have subsequently concluded that some of the song’s features may be Dyer-Bennet’s own contributions, rather than features of the traditional song.¹ In Woody Guthrie’s version of the second verse, for example, the first line speaks of John being a Baptist rather than a Christian, and the third and fourth lines run, “But your holy scripture tells you / That he was a preacher too.” In other words, the features that most puzzled and intrigued me—the lack of clarity about John’s Jewish or Christian identity and the designation of him as “natural”—may have stemmed from Dyer-Bennet himself.² If so, of course, Dyer-Bennet was just continuing the folk tradition by altering the song to fit his own beliefs, predilections, and style.

In the end, it hardly matters whether Dyer-Bennet invented or inherited the ambiguity about John’s Judaism or Christianity or the “natural man” terminology. Those were the elements that spoke to me, along with the song’s powerful evocation of the lonely experience of death, which Paul Jenkins describes in his biography of Dyer-Bennet:

His voice suddenly full of immense power, Dyer-Bennet begins the first verse, stretching “river” taut before releasing it.... The diminishing “soul” at the end of the first verse is a lovely example of Dyer-Bennet’s use of pianissimo, signifying, perhaps, the ebbing of life and leading gently into the chorus. In the third line of the second verse, the word “natural” stretches Dyer-Bennet’s voice to the limits of its range and power, as it suddenly jumps an octave. The startling effort lends true force to the life/death theme of the song, as if to say: Each man must face his death alone, a lonesome end to his journey.³

1 Paul Jenkins, the author of a biography of Dyer-Bennet (see n. 3), mentioned that the “natural man” line, rather than being part of the traditional song, may have been Dyer-Bennet’s own contribution (Jenkins, telephone conversation with the author, Feb. 25, 2021).

2 Indeed, the Carter Family version of the song seems to contradict Dyer-Bennet’s version directly by making John unambiguously Christian: “Some folks say, John was a Baptist / Others say he was a Jew / But the holy Bible plainly tells us / That he was a Christian too.”

3 Paul O. Jenkins, *Richard Dyer-Bennet: The Last Minstrel* (Jackson: University Press of Mississippi, 2010), 40.

A similar sense of confrontation with the power of death pervades Caravaggio's *The Beheading of Saint John the Baptist*. His John, too, is a man crossing the lonesome valley by himself. Art historian John Spike sums up the scene: "Injustice has run its course. The prisoner was dragged outside to have his throat unceremoniously cut. . . . [W]ith his hands bound behind his back, John's dying prayer was spoken into the dirt."⁴ There is a similar starkness to the account of John's death in the two Gospels that narrate it, Matthew (14:3–12) and Mark (6:17–29). This starkness makes it atypical of a martyr story. Such stories usually luxuriate in detail about the sufferings of the martyr and the brave words he speaks to his tormentors, warning that they will soon be punished for what they are doing to him, while he will enjoy paradise. Often the extraordinary courage of the martyr is stressed—the way he endures his sufferings without seeming to feel pain, the way she throws back the threats of her tormentors in their face. In a word, martyr stories are meant to be triumphant.⁵

There is nothing like this in the Gospel accounts of John's execution. Instead, all we are told is that Herodias—the wife of Herod Antipas, ruler of Galilee from 4 BCE to 39 CE [DES: Set small caps]—hated John because he had denounced her marriage to Herod as incestuous. She got back at John by having him arrested and then tricking her husband into condemning him to death by sending Salome, the daughter of her first marriage, to perform an erotic dance before Herod and his guests at his birthday party. When Herod, in his cups, drunkenly promised Salome that he would give her whatever she asked, Herodias prompted her to request John's head on a platter. Herod, although reluctant, acquiesced, not wanting to lose face before his guests (preferring that John lose his head instead). Herod ordered that John be decapitated, and the deed was done.

The Gospel narratives are sparse on detail and as brutally effective as Caravaggio's *Beheading*. They end on a dying note, not with John's vindication but with his disciples fetching what's left of his body to bury it. The sense of violation matches that in Caravaggio's painting, with the slit throat of the Baptist, the executioner reaching for his knife to finish the job, and John's lost words, whatever they were, spoken, as Spike puts it, "into the dirt."

And yet . . . is the violent reality of John's death the end of the story in the Gospels—or, for that matter, in the Caravaggio? Not in the painting, according to Spike:

The four participants are captured in an instant of perfect symmetry, forming a human cupola over John's motionless body. The arc of their backs is repeated in the great portal behind them. An arch is a sacred shape, symbolic of the vault of heaven. . . . Unbeknownst to the men who rob John of his life, they are merely acting out the preordained plan of God. Not seen by anyone, without a single angel or halo in view, the Divine is everywhere nonetheless.⁶

4 John T. Spike, *Caravaggio* (New York: Abbeville Press, 2010), 212.

5 See, for example, 2 Maccabees 6:18–8:42; 4 Maccabees 5:1–18:23; Acts 6:8–7:60; Gospel of Peter 4:10; Tertullian, *The Passion of Saints Perpetua and Felicity* 6:1–4; Babylonian Talmud, Berakot 61b.

6 Spike, *Caravaggio* (n. 4), 212–13.

Whether or not this is a correct interpretation of *The Beheading*, it seems to me to be true to the spirit of the Gospels, in which John's burial scene contains no note of vindication. For the Gospel writers, however, John's story cannot be separated from that of Jesus and the church. John, Jesus, and Jesus's disciples are interrelated and overlapping figures: first John is handed over, suffers, and dies (Mark 1:14, 6:17–29); then Jesus is handed over, suffers, and dies (Mark 9:31, 10:33, 14:10–11, etc.); then his disciples are handed over, suffer, and die (Mark 13:9–13). In Matthew both John and Jesus preach the same message, that of the imminent arrival of the dominion of God (3:2, 4:17). In Luke the parallels between the two men are so strong that Luke, probably unhistorically, turns them into cousins (1:36).

Therefore, for the Gospel writers at least, the element of vindication—absent from their accounts of John's demise—is supplied by the narrative of Jesus: since John points forward to Jesus, and Jesus does not remain in his grave, Jesus's resurrection vindicates John as well. Over the whole narrative of John's death, therefore, and unbeknownst to the malicious or impotent actors in the story, there looms the invisible plan and presence of God, the “it is necessary” that structures the entire narrative (see Mark 8:31; 9:11; 13:7, 10) and that ultimately points toward a redemptive future. Or, as “Lonesome Valley” puts it, “Jordan River is wide and deep / But you can't drown a good man's soul.”⁷

John through the Lens of Faith

The narrative of the execution of John the Baptist in the Gospels is a masterpiece of biblical storytelling that combines elements of Realpolitik, soap opera, and horror. It is a compelling story. No wonder it has inspired literature; music, such as Richard Strauss's opera *Salome*; and so much great art. Who can forget the grisly detail about John's decapitated head being delivered to Herodias (presumably still at the banquet) *on a platter*? Isn't that a dainty dish to set before the queen?

But scholars are a suspicious lot. When a story is *too* good, they begin to question its historicity. In this case, there are additional reasons for suspicion.

For one thing, a short account of John's ministry and death by the early Jewish historian Josephus mentions neither the dancing girl, nor her malicious mother, nor Herod's reluctance to execute John.⁸ In Josephus's account, Herod dispatches John willingly, and for political reasons: John is gaining a following,

7 Rich Warren told me that he was responsible for displacing Dyer-Bennet's rendition of “Lonesome Valley” from its place at the end of “The Midnight Special” when he took over as sole host in 1996. “I always felt,” he wrote, “that ‘Lonesome Valley,’ although a beautiful and profound song, was far too depressing a song with which to end a radio program.” I wrote back, “I guess I don't find ‘Lonesome Valley’ depressing, because I see it in the context of other folk songs and Christian theology in general, in which the crossing of the ‘lonesome valley’ is only a penultimate moment. That is, it all depends on what you think is on the other side of the Jordan (or if you think there's anything there at all).” Warren, email correspondence with the author, Aug. 24, 2012.

8 *Jewish Antiquities*, 18.116–19.

and Herod rightly fears that he might end up leading a revolt.⁹ For another thing, the Gospel story echoes the Old Testament book of Esther in the description of the girl “pleasing” the king and his promising to reward her “up to half my kingdom” (Esther 2:9, 5:3). In times past, churchmen saw such correspondences as evidence that the God who directed Old Testament history was the same one who stood behind New Testament events, and that this God deliberately created historical correspondences between Old Testament “types” and New Testament “antitypes.”¹⁰ Modern scholars, however, tend to see them as evidence that the New Testament story or its later development has been shaped by the authors’ own knowledge of the Old Testament.

Once historical doubt gets started, it is hard to put the brakes on. This extends even to the matter of John’s acknowledgment of Jesus as the Messiah, which is central to the portrayal of John in the New Testament and in later Christian tradition, including Christian art. In Christian iconography, which emerged after the Gospels were written, John is usually portrayed as a believer in Jesus’s divinity—for example, when he is accompanied by a lamb (the symbol of Christ as the “Lamb of God”) or when he carries a cross-shaped staff (a motif present, though in an understated manner, in Caravaggio’s paintings of the Baptist from 1598 and 1602).¹¹ Even depictions of John’s death are often Christianized, such as when his decapitated head displayed on the fateful platter evokes the image of a eucharistic wafer on a communion plate.¹²

The apotheosis of this approach is the famous Isenheim altarpiece of Matthias Grünewald, painted between 1512 and 1516. Here a lamb stands at the Baptist’s feet holding a cross in the crook of its right foreleg as blood drips from its chest into a communion chalice. John looms over the lamb with an open Bible in his left hand, while he points with the oversize, bony index finger of his right hand to the focal point of the altarpiece, the lacerated body of the crucified Christ. Above John’s outstretched arm appear the words attributed to him in the last of the canonical Gospels: “He must increase, but I must decrease” (John 3:30). In the Gospels and in most Christian art, then, John is absolutely subordinate to Jesus.

9 Though Matthew basically follows Mark’s version of the story, he does introduce a change here: it is Herod, not Herodias, who wants to kill John, but he fears John’s popularity with the masses (Matt 14:5). This confirms Josephus’s basic picture and casts doubt on Mark’s portrait of a Herod who is well disposed toward John. Mark’s portrayal of Herod sympathizing with John and trying to protect him is similar to his picture of Pontius Pilate sympathizing with Jesus and trying to save him from crucifixion (Mark 15:1–5). In actuality, Pilate, like Herod, was ruthless (see Luke 13:1; Josephus, *Jewish War* 2.169–77; *Jewish Antiquities* 18.60–62, 85, 87; Philo of Alexandria, *Embassy to Gaius* 299–305). Early Christians often emphasized rulers’ sympathy for them to show that this supposedly subversive movement was actually no threat to properly constituted authority.

10 A classic treatment of typology is Erich Auerbach, “Figura,” in *Scenes from the Drama of European Literature* (1938; repr., Minneapolis: University of Minnesota Press, 1984), 11–76.

11 In Caravaggio’s charming 1604 painting of a youthful John, the prophet is accompanied by a ram. See Sergio Guarino, “John the Baptist,” in *Caravaggio*, edited by Claudio Strinati (Milan: Skira, 2010), 131. Guarino notes the sacrificial significance of the ram (see, e.g., Genesis 22:13) and claims that in the painting the ram is “embraced by the Baptist because the principal subject is not the Precursor but the sacrifice of Christ, the Redemption.” This seems plausible, but the ram may also be Caravaggio’s variant on the more common lamb symbolism.

12 See Isabel Combs Stuebe, “The Johannisschüssel: From Narrative to Reliquary to Andachtsbild,” *Marsyas* 14 (1968–69): 6–7.

But how historical are these sorts of portrayals of John's self-abnegating mission? Here, as elsewhere in the Gospels, memories of John and Jesus seem to have been refracted through the lens of Christian faith. A core of historicity may be present, but the stories have been shaped to meet the needs of the church. As a New Testament scholar famously put it, "In the beginning was the sermon."¹³

This can be seen, for example, in the way in which John's fealty to Jesus becomes more pronounced as the Gospels develop over time. In the earliest account, that of Mark, John does not recognize Jesus as the Messiah when Jesus comes to John at the river Jordan to be baptized by him. Mark suggests that Jesus was the one whom John prophesied by juxtaposing John's reference to a coming figure—one who will baptize with the Holy Spirit—to the account of Jesus's baptism, in which the Spirit descends upon him like a dove (1:7–11). But in Mark, the Baptist is not privy to this supernatural action; it is a vision experienced privately by Jesus alone. Matthew and Luke, retelling Mark's story, imply a more objectively perceived occurrence. Even so, they do not make John's baptismal recognition of Jesus's divinity explicit (Matt 3:13–17//Luke 3:21–22). Indeed, they later contradict that possibility when they portray John, at the point of death, first beginning to consider the possibility that Jesus *might* be the Messiah (Matt 11:2–3//Luke 7:18–19). Only in the latest and most theological of the Gospels does the Baptist explicitly say that as he baptized Jesus, he saw the Spirit descend upon him and realized then and there that he was the Christ (John 1:32–34).

The witness of Josephus is also relevant here: while mentioning John and Jesus in separate passages, he does not connect the two figures.¹⁴ This also may be somewhat misleading. Jesus probably began his public life within the Baptist's movement, if only because it is hard to see why a Christian would invent such a link when Jesus's participation in John's "baptism of repentance for the forgiveness of sins" created such problems for the later church (Mark 1:4). The fact remains, however, that if John's main purpose had been to promote Jesus, Josephus probably would have noted it.

The Historical Baptist and the Baptist of Faith

So who was John really? Or if that seems too difficult a question to answer straight-away, who did he *think* he was?

We can start with the fact that John was a baptizer. That is, he dipped into the Jordan those who came to join his movement of repentance and apocalyptic expectation. The symbolism of washing is ubiquitous in religions throughout the world, signifying a removal of the impurities and sins that cling to all human life.

¹³ The adage is usually attributed to Martin Dibelius, but the source is actually a summary of Dibelius's thesis by Eric Fascher, as quoted in Vincent Taylor, *The Formation of the Gospel Tradition* (London: Macmillan, 1949), 12.

¹⁴ *Jewish Antiquities*, 18.116–19, 18.63–64.

According to the Torah, water rites purify people from the ritual “uncleanness” that results from contact with life-giving and death-dealing processes such as sex, menstruation, and mortality itself. But the later prophetic writer Ezekiel uses these cleansing rituals as a symbol for what will happen in the endtime, when God purges his people from their sins and impurities through an outpouring of his divine Spirit (Ezekiel 36:25-27). This is apparently what John thought was happening in his own baptismal ministry: the new age of God’s grace was breaking into the world, and therefore, people were being cleansed by the Spirit.¹⁵

John, then, may have seen himself, rather than his erstwhile disciple Jesus, as the central figure in the revelation of God’s will for the cosmos. During his baptismal ministry, God’s grace was beginning to flood the world; people were experiencing an unprecedented moral renewal; and the long captivity of Israel was coming to an end. Jesus was apparently inspired by similar apocalyptic visions, which he probably derived, at least in part, from John. If so, both were in for a disappointment. John ended up decapitated by Herod, Jesus crucified by Pilate. To return again to Caravaggio’s *Beheading*, this is what it demonstrates so starkly: the abuse of the good, the triumph of the violent, the end of the dream of worldwide redemption. The painting might bear as its rubric the final words attributed to Jesus in both Matthew and Mark: “My God, my God, why have you forsaken me?” (Mark 15:34; Matt 27:46). In classical Christian theology, of course, such despair is overridden by the belief that Jesus’s life did not end on the cross.

To return, then, to Dyer-Bennet’s version of “Lonesome Valley”: John was probably not a Christian in any conventional sense but was, instead, an apocalyptic Jew, like Jesus himself. But above all, he was, again (like Jesus), a “natural man”—one exposed to the same assault of seemingly meaningless death that we too ultimately face and that Caravaggio’s *Beheading* depicts in such an indelible way. Death comes as an outrage, a disfigurement, a snuffing out of possibility, the end of the dream. This is what awaits us all—a fact that Caravaggio underscores by signing the painting—the only time he ever did so—in the same blood-red paint that streams from the Baptist’s throat.

But that, again, may not be the end of the story. John’s life may have ended in loneliness and despair, but that is not the way he is remembered. He may have seen himself as the vanguard of God’s triumphant return in power to reclaim the world and may therefore have seen his own death as the end of hope. But he has been remembered, when he is remembered at all, as the precursor to Jesus, his bony finger pointing to Jesus’s crucifixion and resurrection. This image of him may depart from his own self-conception, but which of us knows who we truly

¹⁵ In the Gospels, John distinguishes his water baptism from the coming baptism in the Spirit by “the Stronger One” (Mark 1:7–8//Matt 3:11–12//Luke 3:16–17; John 1:26–34). In my book on the Baptist, I argue that this reflects Christian theology, in which only Jesus imparts the Spirit (see, e.g., Acts 19:1–7; John 7:39; Romans 8), more than it reflects historical memory (Joel Marcus, *John the Baptist in History and Theology* [Columbia: University of South Carolina Press, 2018]). The assertion has been controversial.

are? Self-estimates are, after all, provisional, and often delusive. For those whose lives are shaped by the biblical narrative—as John the Baptist’s life certainly was—the ultimate truth of a person’s identity lies hidden in the mind of God.

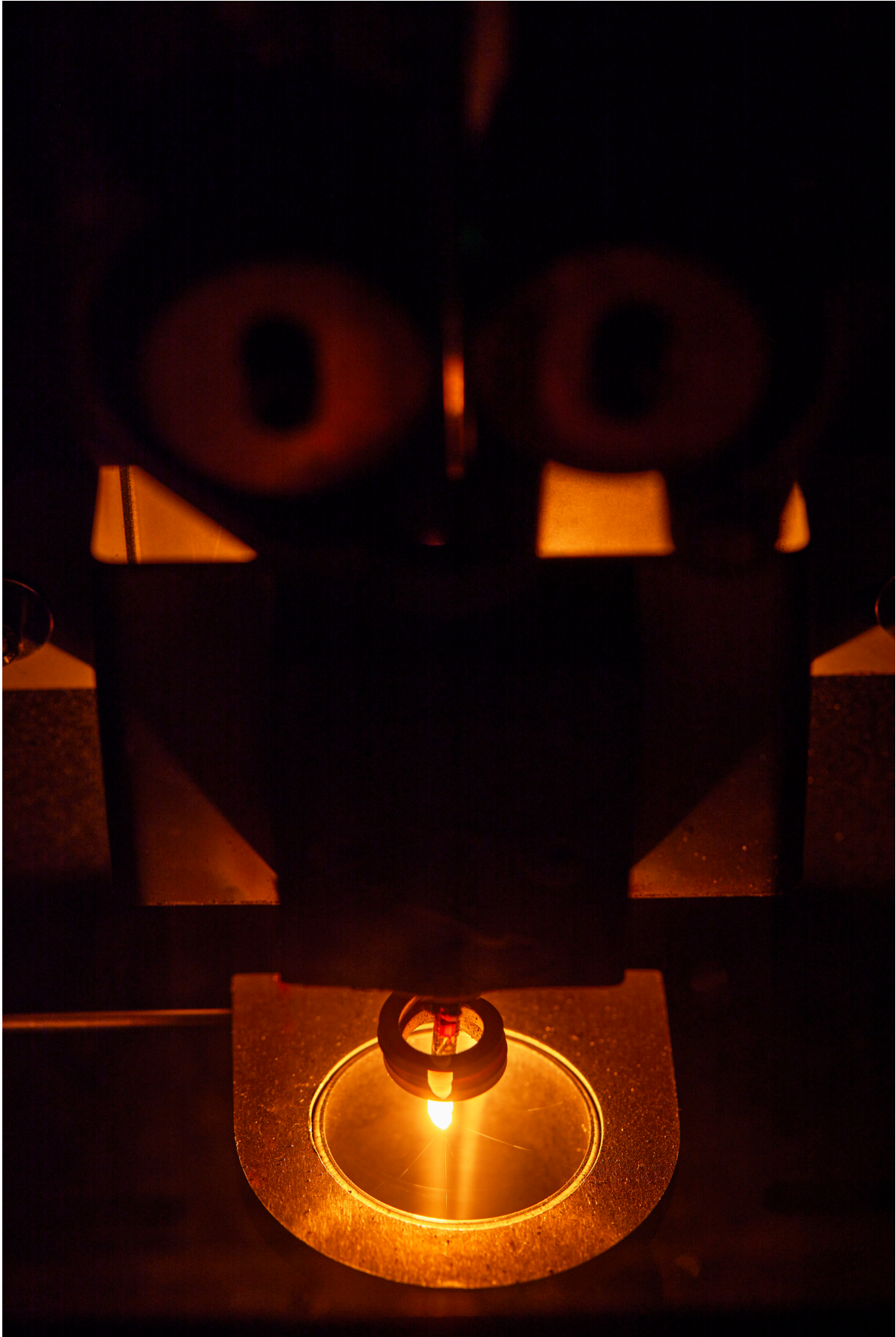

CRUELTY AND REDEMPTION: A CONVERSATION WITH MARIA CHRISTINA TERZAGHI

QUESTIONS BY KEITH SCIBERRAS
AND JEFFREY USLIP

What commonalities, if any, exist between the context by which art was made in 1608 and that of today?

First of all, always the product of human thought and emotions (those of the artist) immersed in a reality of diverse human beings to whom it is addressed. If an artist lived in isolation, it would be meaningless to express oneself: expression, more or less implicitly, always involves someone listening. On the other hand, the recipient, client or public that is, influences the artist's expression in one way or another. Not to mention that artists are totally interwoven within the cultural and social reality in which they were raised. These connections existed in 1608, as they do today, although the cultural and religious contexts are completely different. However, there is one major difference: in 1608, painting was almost the only means of presenting images of reality. Humankind has always felt the need for stories (let's think about how old is the greatest creation of fabulae in the West: the Homeric poems), and there has always been the desire to see them illustrated, whether belonging to myth, fantasy, religion or ancient history. During our time, the means of producing images have substantially diversified, in line with technology. In 1608, if one wanted to illustrate what had happened to a personage like St. John the Baptist, one had to ask a painter. This was, more or less, the case with Caravaggio.

**How would you characterize the agency of Caravaggio's work in 2022?
What is its potential to provoke renewed social consciousness?**

Caravaggio is one of the five best-known artists of the modern age. As early as 1951, when Roberto Longhi organized the first major exhibition dedicated to the artist at the Royal Palace of Milan (which had been bombed a few years earlier, during the Second World War), the exhibition was seen by 250,000 visitors in under three months. This was an extraordinary success. In 2010, at the exhibition dedicated to the artist in Rome on the occasion of his centenary, it was decided as a special accommodation to keep the exhibition open overnight on the eve of its closure, in order to allow visitors who had not yet done so to view the exhibition. I think the question we have to ask ourselves is: why? What does Caravaggio evoke in the heart of contemporary humans that, with due respect to all, neither

Raphael nor Michelangelo (not to mention Velázquez, Rubens, or Rembrandt)—to mention the greatest masters—was able to elicit? I believe that Caravaggio’s painting, now as in 1603, has always been experienced as absolutely modern—even contemporary. In 1603 the biographer Karel van Mander claimed that Caravaggio’s manner was “extraordinarily well suited to be followed by young artists.” Even today, Caravaggio’s painting continues to be characterized by a truth and humanity that have not ceased to engage those who study his works. However, there is another aspect, which I discovered in greater depth while working on the exhibition dedicated to Caravaggio’s *Judith* at Palazzo Barberini; Caravaggio makes things happen. His works are not stories narrated in a didactic manner. He thinks that the peak of emotion constructs the story; there is no need for details. His actions are played out in an instant: the scream of Holofernes while the beautiful Judith kills him in his sleep. It is that moment that tells the whole story; the rest are details that can be left to idle chatter. In Caravaggio’s paintings, there is always a human emotion that fires up the entire sense of the story—hence the reason they never go out of fashion. I believe that, if we can speak of an awakening of consciousness, this is one of the possible senses: there is something universal in the human being that transcends time and space and that is the consummate interest of humankind, far beyond social status.

Why do you think the collective imaginary in 2022 should care about Caravaggio’s work? What do you think a contemporary audience can learn from Caravaggio’s artistic practice?

I believe that the passion for truth and for making things happen is Caravaggio’s greatest legacy to the modern age. Caravaggio placed the models in poses; he was obsessed with adhering to the reality of human beings. I wonder: does reality still have something to say to modern man, or do we think that with our reason we have already comprehended everything? I believe that now, more than ever—and especially during a pandemic, which has swept away so many certainties and a way of life that we took for granted—the question is a burning one. For Caravaggio, reality was the master, not his mind and not even his powerful technique.

Ostensibly, Caravaggio depicted the act of decapitation as it unfolded, and *The Beheading* was the only painting he signed, and he signed his name within John’s spewing blood. Why do you think Caravaggio chose to depict this particular event, in this particular way, for this particular location?

In this painting, which I find extraordinary especially for the relationship between the figures and the space, one can read the entire tragedy of the moment that Caravaggio is experiencing. It is the only signed canvas, and it is signed with “fr.”

preceding it—that is, with the abbreviation for *frater*. I absolutely think that it cannot be a coincidence: Caravaggio signed [with his given name] as “brother Michelangelo,” not just Michelangelo. There is a sort of pride in those two letters, a feeling of belonging that perhaps he’d never experienced before, a societal redemption not overly subdued but, rather, to be proudly exhibited. On the other hand, it seems to me that there is also an identification with the unjust fate that befell the Baptist. The horror of that death in order to satisfy the caprice of a spoiled girl and the intentions of an unscrupulous mother prevailed over human reason, a tragic fate that Caravaggio captured masterfully in the gesture of the elderly servant who clutches her hands to her head. Perhaps in that “frater,” there is also the secret hope of escaping such a seemingly meaningless death.

Do you see Caravaggio’s work as part of a larger humanist project?

Of course! Caravaggio dedicated his entire existence as a man and as an artist to the depiction of the human being. He isn’t interested in landscapes. And regarding still lifes, of which he was also a master and which must have served him well, he paints a few of them, just enough to make a name for himself. Humanity, in all its forms, is his lifelong interest.

How can Caravaggio’s work be understood to depict or connote moral redemption?

Certainly, in Caravaggio’s works, the idea of redemption is very much present. I believe it is important to outline this aspect from two perspectives:

The first of these relates to the interest in the human being in all its forms we discussed earlier: from the poor pilgrims begging for beneficence, to the common women who appear as queens (for example, in the *Madonna dei Palafrenieri* at the Galleria Borghese in Rome), to Christ’s body itself, so perfect and tormented (in *The Flagellation* at the Museo di Capodimonte in Naples), extending to the young beauties of *The Cardsharps* or to the *The Fortune Teller* who promises good fortune and tricks her clients. If humankind is so interesting, it is not because human beings are free from defects but because in their being and becoming, there is the palpable dawn of a certain optimism. The final word cannot be about all these human miseries: the human heart is much greater; the mere fact of having been created makes humans greater. Humanity painted by Caravaggio, however base, is in fact never feral; it always retains a sense of dignity. Personally, in this aspect, Caravaggio seems to me very similar to Dostoevsky.

The second aspect that emerges from Caravaggio’s works is imperfection. His humanity in some way or other always has its earthly imperfections, even in the case of saints—the *Saint John the Baptist* at the Nelson-Atkins Museum of Art

in Kansas City, a handsome and doomed young man, or the *Saint Jerome Writing* at the Galleria Borghese with his withered skin—and therefore is intensely moving. I believe that Caravaggio understood very well that on this earth we can only be redeemed. The canvas of reality is always torn, slightly or considerably, and must be continuously washed and mended. For perfection we must wait for another world, infinitely more real and more human, as foreshadowed by Caravaggio in his paintings.

DISSIPATIO

ARCANGELO SASSOLINO

The empty darkness of that wall, of those stones, of everything inanimate—in Caravaggio’s painting, that void seems to be the very condition of the scene, what makes possible the vibrant, throbbing light that makes those bodies live and move. This radical contrast between light and dark makes the scene into something that happens before our eyes, not merely something that will happen or has already happened.

It is this contrast that interests me—or, rather, the idea that only through the conflict and unresolved tension of forces can we see, if only for an instant, and in the form of a blinding light, the origin of things: an origin that, coming from nothing and destined to return to nothing, exists only in the here and now of its appearance. An origin that appears and that, at the very moment of its appearance, is no longer there.

What I am trying to capture is the change of state, that instant in which something is becoming something else, that energy and power that exist in the flash of absolute instability between the moments of equilibrium that are the before and the after.

That’s why I decided to work on metal and its transformation.

About eight millennia have passed since human beings began to use metals: copper, gold, iron, aluminum. Metals are characterized by strength but also by ductility. They appear inert, but they conduct energy and heat.

The fork on our table, the wheel of the train, the airplane, the components of an engine, the ring on our finger, the monument in the square, a scalpel, a bullet: before being what they are, all of these objects were incandescent liquid. All the metal that we see, that we touch, that we use, and that constitutes the skeleton of the vital world within which we move is solidified in the darkness of a mold, to then pass through a die and thus cool against, or inside, something.

I want to free metal from that closed form, to expose its luminous liquid origin.

Once melted, metal is no longer simply static, no longer something that merely exists, unchanging. Instead, it expands within a chronological dimension of appearance and disappearance: it becomes time itself.

Steel is created only at very high temperatures, and when energy and heat bring it back to its original liquid state, it glows with red-hot light; it becomes stolid hardness only when that light goes out.

Only in the change of state, and therefore only in living time, does steel become light.

Diplomazija astuta is a work about continuous loss, about the impossibility of holding back, about the inexorable and unstoppable flow of all things. But

it's also about the fact that being is revealed only in vanishing, that light is an evanescent interval of darkness.

Something keeps dissipating, consuming, yielding; the molten drops ceaselessly appear, fall, and vanish. I am trying to scan time—that which both creates being and consumes it—through something equally elusive.

Maybe mine is, at its core, a work about the open wound that is life.

Why can't sculpture flow like time instead of being a cold, rigid monolith devoid of the vital energy that produced it?

Instead of fixing the instant of the passage, making it once again something static, I show the passage itself: the appearance and the disappearance, the glowing, ephemeral limit that divides and connects the twin darknesses of before and after.

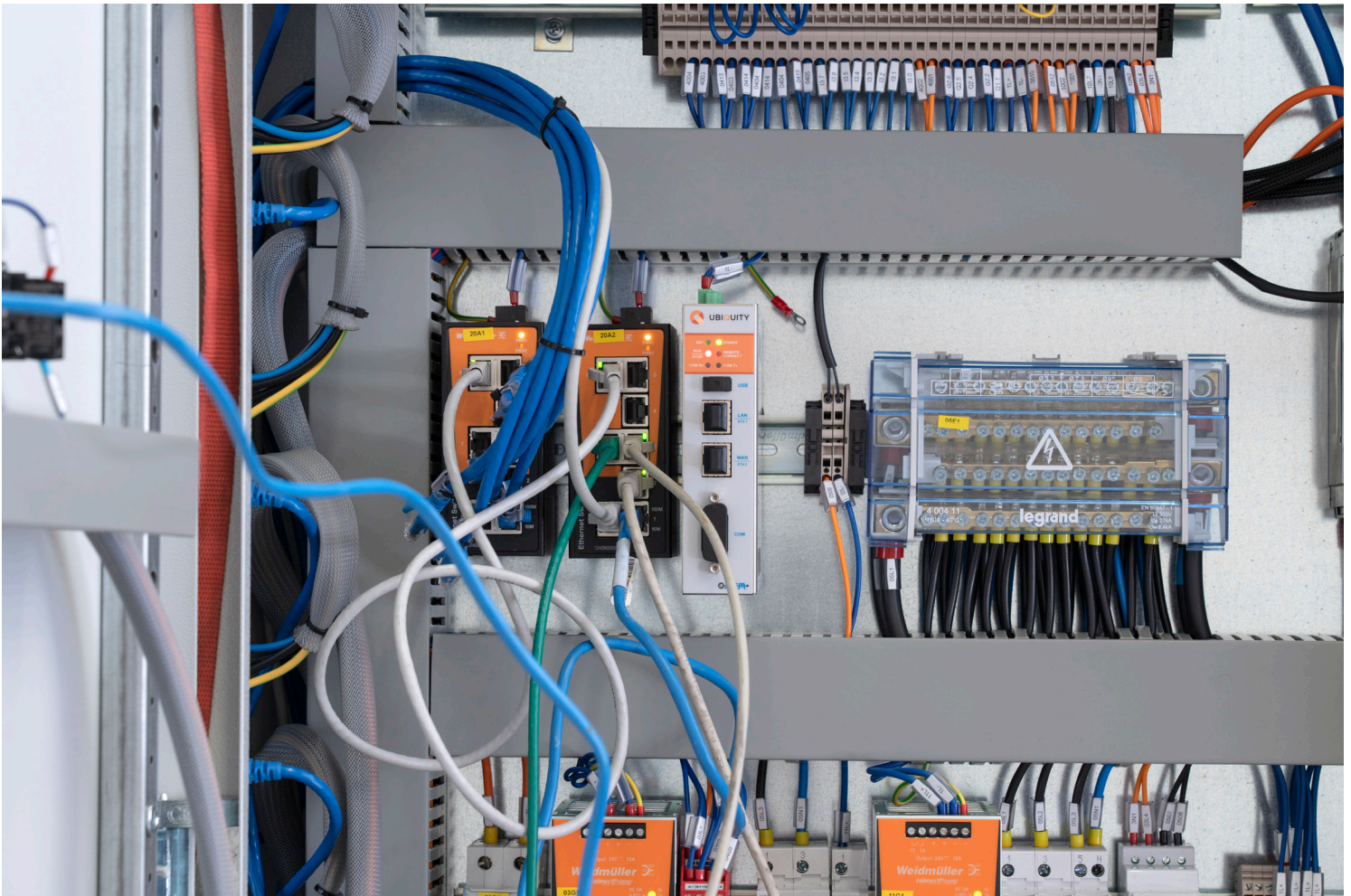

HARDOX 450

4996

12000-2500-15.0

← DIM 5474

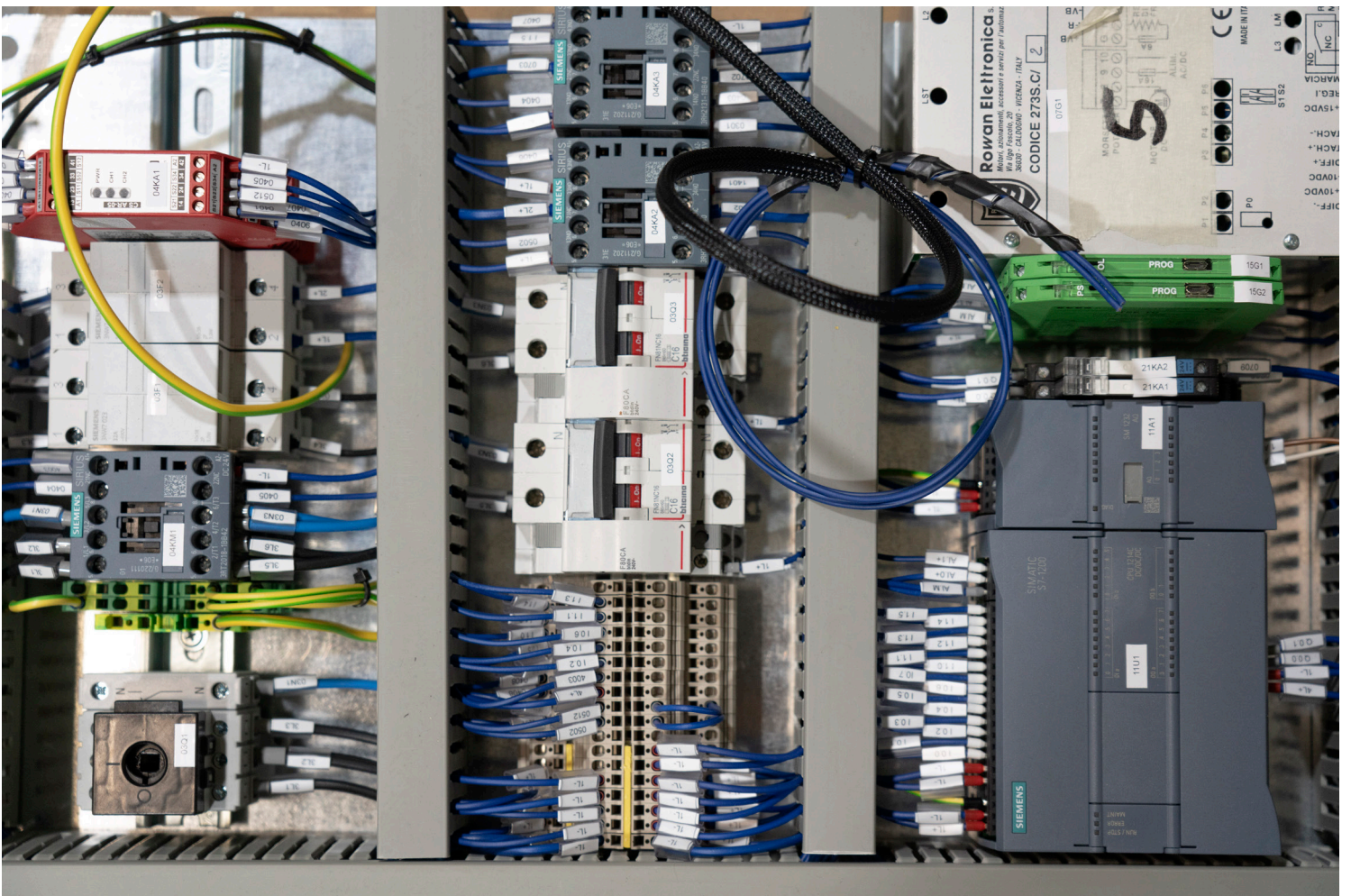
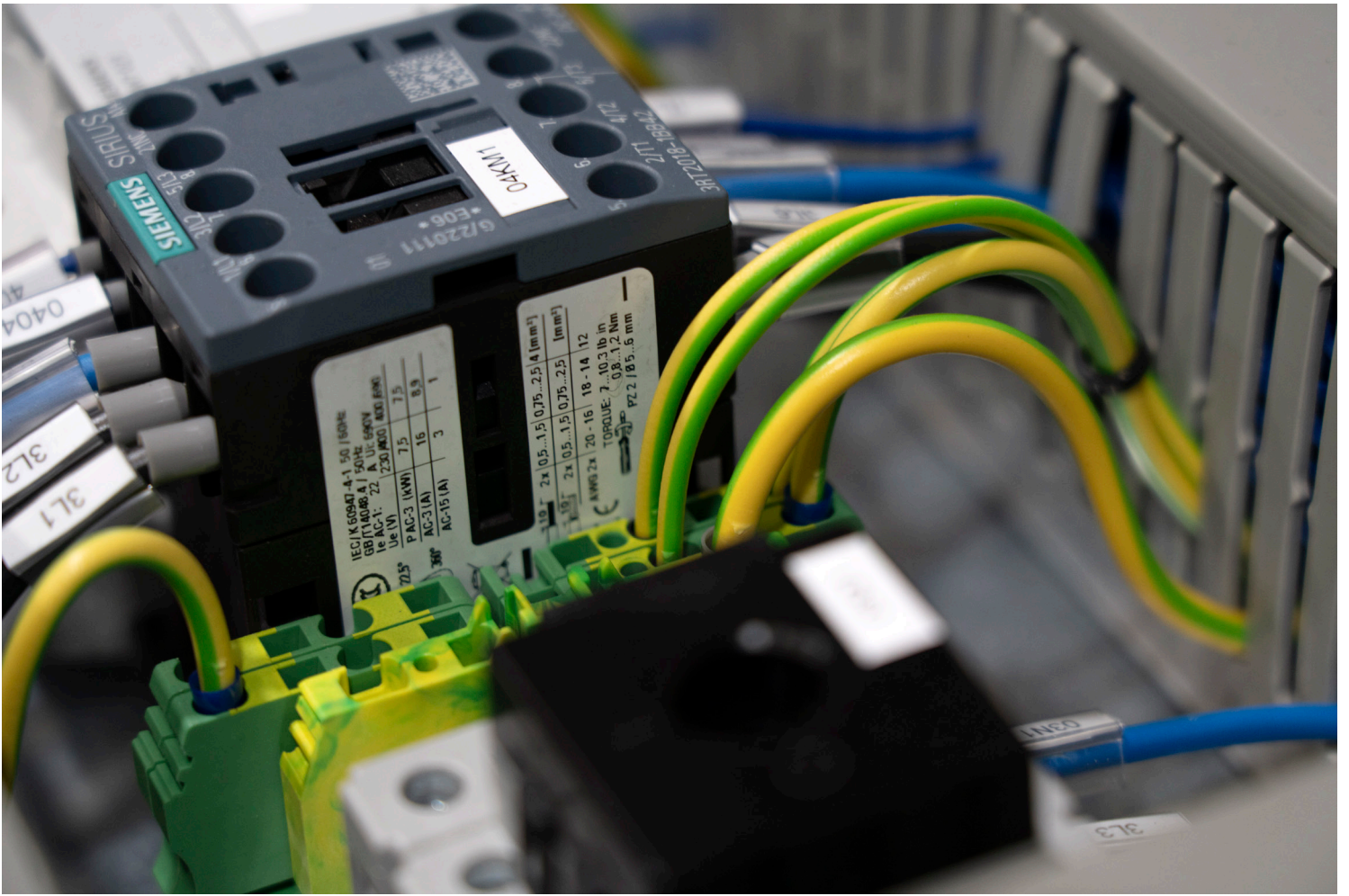

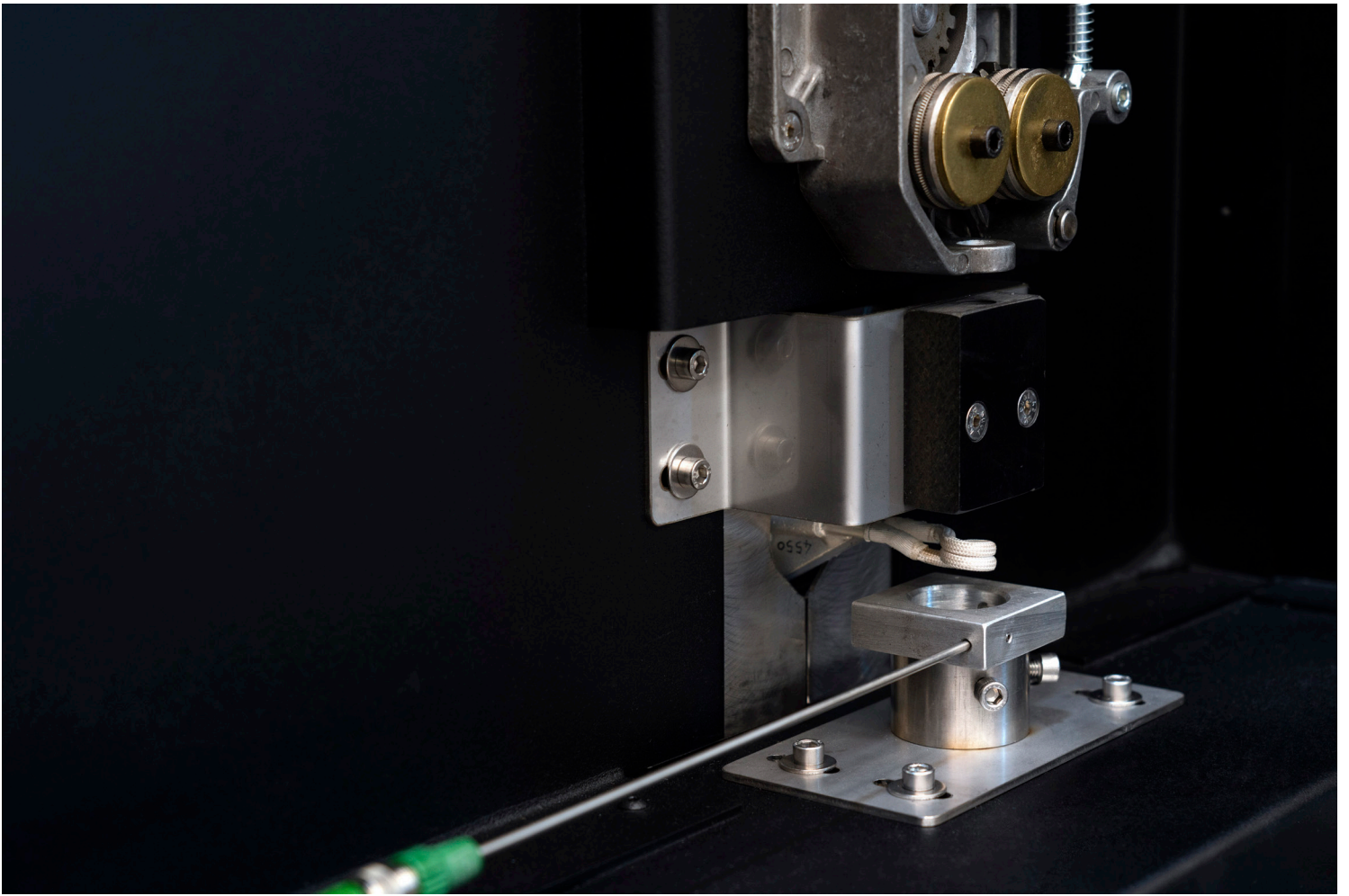

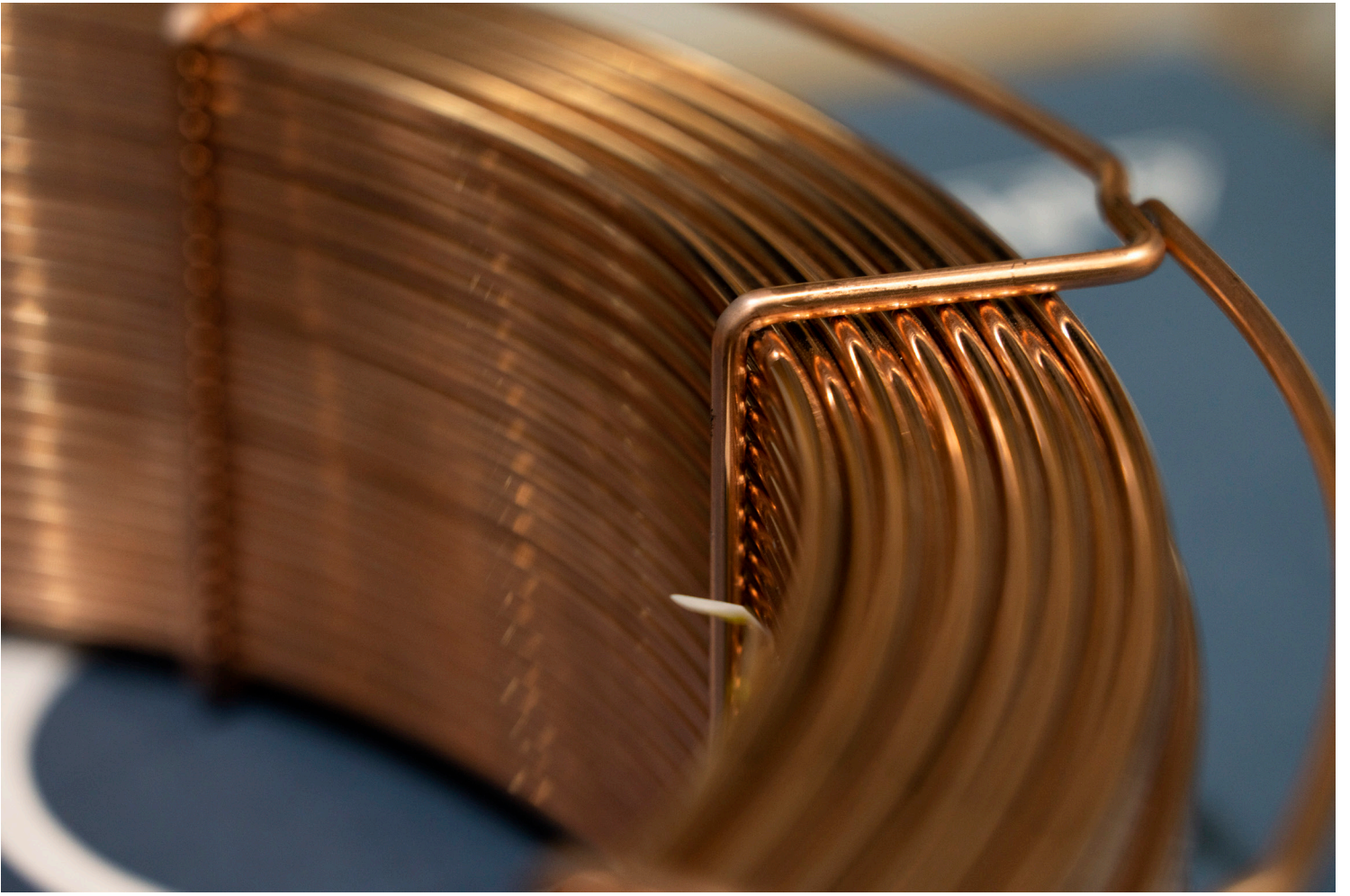



ST101001 - Massa ~ N/A

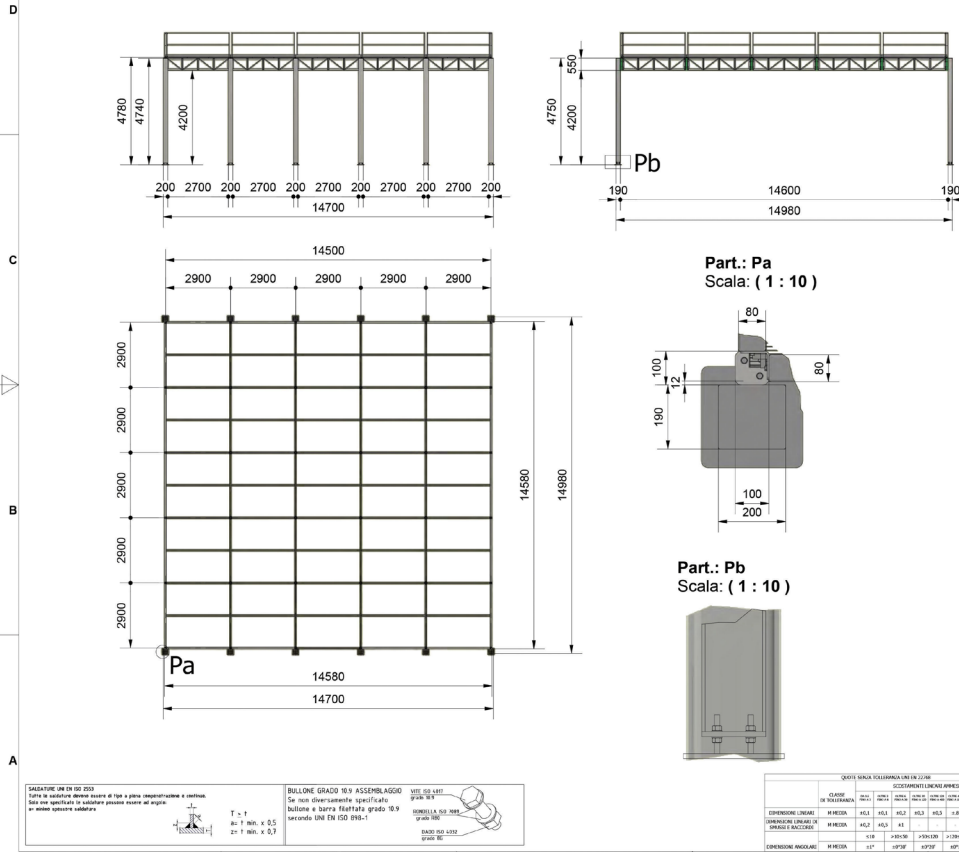

NOTE/NOTES:

Rev Descrizione/Description: Aprv Chk'd Data/Date:

Autore/Author:

ARCANGELO SASSOLINO
info@arcangelosassolino.it

Committente/Client:

Costruttore/Constructor:



MARCON SRL
Via A. De Gasperi, 35 36060
Pianezze (VI) Italy
info@marconsrl.com
Tel. +39 0424/781061 Fax 470777

Studio progettazione/Design Engineer:



Engineering and Consulting
Ing. Ermene Spagnolo
Via dell'Industria, 22
Marostica (VI) - Italy
www.ingspagnolo.it
Tel. +39 0424/471894 Fax 475943

Titolo/Project Title: **MAR-0121-MALTA-BIENNALE ARTE VE2022**

Oggetto/Object: **Oggetto: BOZZA STRUTTURA**

Descrizione/Description:

Approvato/Approved:

Data/Date:
01/10/2021

Progettato/Designed:

Disegnato/Drawn:

Controllato/Checked:

File di rif./Model File Ref:

ST101001.idw

Dim Igi/Sheet size: A3

Revisione N°/
Revision No: 00

Disegno N°/Drawing No:

MAR0121-MK-ST101001-2 di 2

ST201001 - Massa ~ N/A

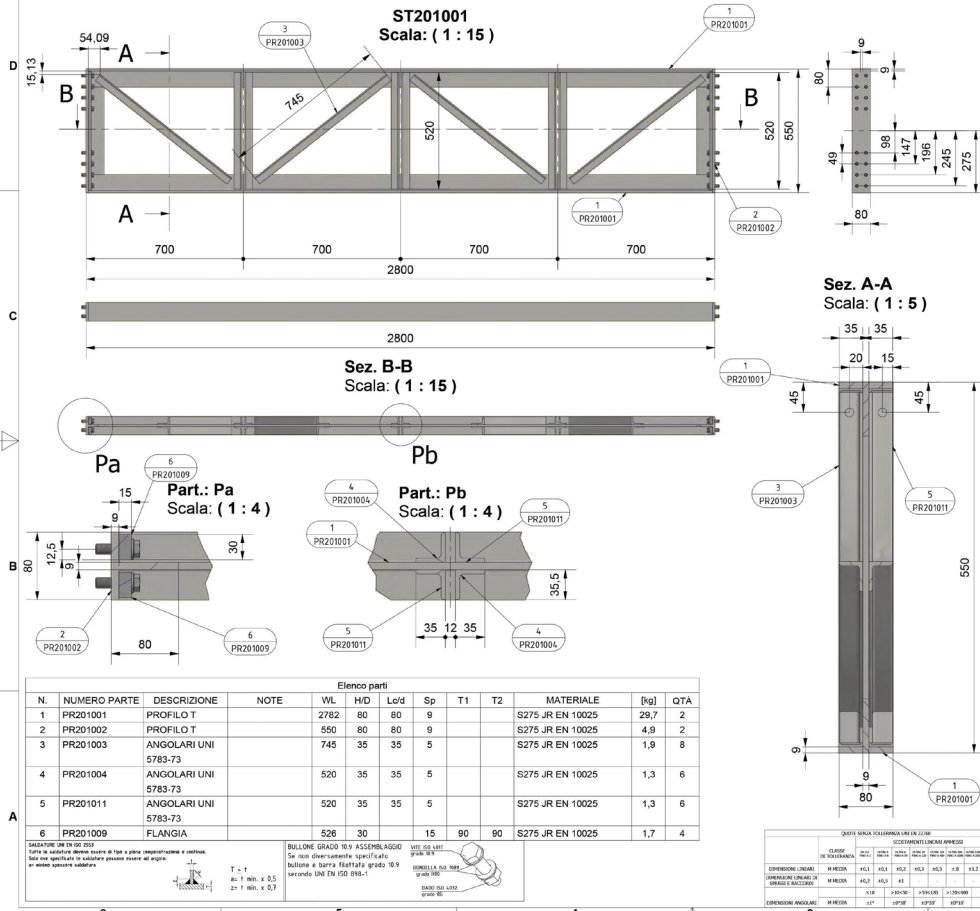

NOTE/NOTES:

Rev Descrizione/Description: Aprv Chk'd Data/Date:

Autore/Author:

ARCANGELO SASSOLINO
info@arcangelosassolino.it

Committente/Client:

Costruttore/Constructor:



MARCON SRL
Via A. De Gasperi, 35 36060
Pianezze (VI) Italy
info@marconsrl.com
Tel. +39 0424/781061 Fax 470777

Studio progettazione/Design Engineer:



Engineering and Consulting
Ing. Ermene Spagnolo
Via dell'Industria, 22
Marostica (VI) - Italy
www.ingspagnolo.it
Tel. +39 0424/471894 Fax 475943

Titolo/Project Title: **MAR-0121-MALTA-BIENNALE ARTE VE2022**

Oggetto/Object: **Oggetto: BOZZA ARCHERECCIO**

Descrizione/Description:

Approvato/Approved:

Data/Date:
28/10/2021

Progettato/Designed:

Disegnato/Drawn:

Controllato/Checked:

File di rif./Model File Ref:

ST201001.idw

Dim Igi/Sheet size: A3

Revisione N°/
Revision No: 00

Disegno N°/Drawing No:

MAR0121-MK-ST201001-2 di 3

Nodi:3110584
Elementi:1756420
Tipo: Sollecitazione di Von Mises
Unità: MPa
11/04/2022, 09:18:41

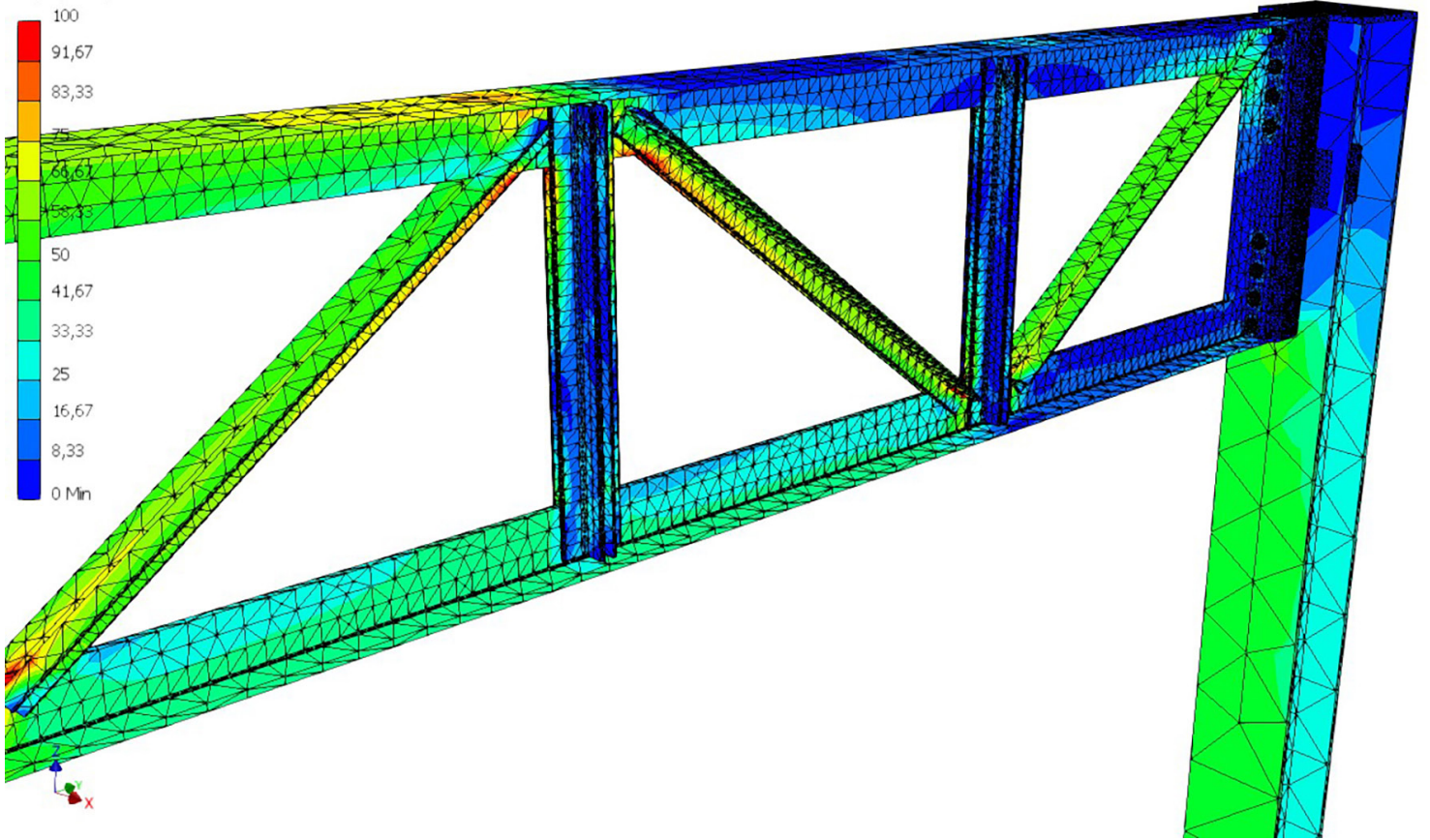

Tipo: Sollecitazione di Von Mises
Unità: MPa
11/04/2022, 08:21:34

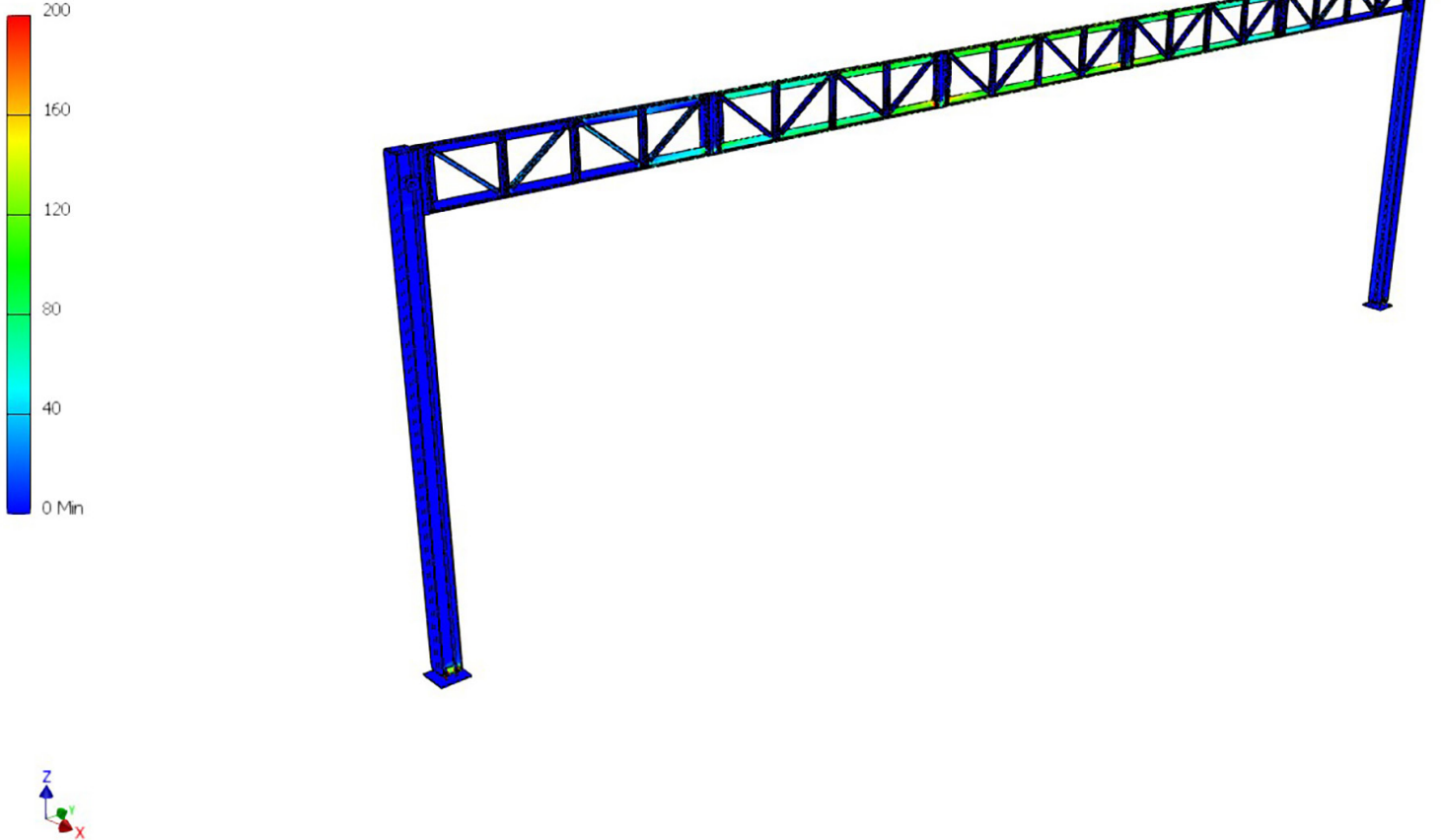

THE DRAMA OF STILLNESS

BRIAN SCHEMBRI

A journey in time,
The violence of the inevitable,
The drama of stillness,
The tension of silence,
The noise of death,
The serenity of resignation,
A story of life.

Discussing the concept of the project *Diplomazija astuta* (*Cunning Diplomacy*) with the team of artists and curators, I realized that there was a fortunate connection between the importance given by the project to the number 7 (as derived from the seven characters in Caravaggio's *The Beheading of Saint John the Baptist*) and another work linked to John the Baptist. In fact, my musical score is inspired by the medieval hymn "Ut queant laxis," an eighth-century Gregorian hymn honoring the saint.

As is well known, the first six of the seven music note names (*ut re mi fa sol la*), established by music theorist Guido d'Arezzo in the eleventh century, were derived from the first syllable of each of the first six strophes of this work. The seventh note name comes from the initials of Saint John (Sancte Iohannes) cited in the seventh strophe—hence the note name *si*. In my score, these seven note names echo the seven characters in Caravaggio's painting, a number that is also reflected in the seven pools of the installation, which interpret my score.

As various musical treatments of the hymn pattern interact and engage in dialogue with one another, I introduce rhythmical excerpts from works by two important Maltese composers, Carlo Diacono and Charles Camilleri. These include rhythmical motifs from two different hymns composed by Diacono, both of which have the same Latin text as "Ut queant laxis." I also borrow a few rhythmic motifs from Camilleri's major twentieth-century organ work, the *Missa Mundi*, specifically from three of its movements: "Fire over the Earth," "Fire in the Earth," and "Communion."

Forming an integral part of the installation, the musical score aims at articulating the movement of the falling molten steel balls (with the ensuing visual and sonorous effects) in a musically organized manner—a sort of percussive score performed by the installation itself, which also organizes the movement of the falling steel balls into a dramatically choreographed visual event. Guiding the timing and frequency of each descending ember and ordering the sequence in which the machines operate, I challenge the installation to interpret my percussive score in aleatoric dialogue among itself, its various components, and my musical composition.

What we have is a journey in time, starting with an eighth-century hymn that in the eleventh century became the primary source for the establishment of Western music notation; it, in turn, is articulated in a classical eighteenth- and nineteenth-century rhythmical mode as it interacts with two completely contrasting twentieth-century aesthetics (those of the modern Maltese composers)—all this through the lens of the twenty-first-century.

Diplomazija Astuta

Brian Schembri (2022)

♩ = 110 ♩ = 96 ♩ = 110

1 9/4 9/4 9/4 9/4 9/4 9/4 9/16

2 9/4 9/4 9/4 9/4 9/4 9/4 9/16

3 9/4 9/4 9/4 9/4 9/4 9/4 9/16

4 9/4 9/4 9/4 9/4 9/4 9/4 9/16

5 9/4 9/4 9/4 9/4 9/4 9/4 9/16

6 9/4 9/4 9/4 9/4 9/4 9/4 9/16

7 9/4 9/4 9/4 9/4 9/4 9/4 9/16

♩ = 96

1 9/16 3/8 3/4 9/16 3/8 3/4 9/4

2 9/16 3/8 3/4 9/16 3/8 3/4 9/4

3 9/16 3/8 3/4 9/16 3/8 3/4 9/4

4 9/16 3/8 3/4 9/16 3/8 3/4 9/4

5 9/16 3/8 3/4 9/16 3/8 3/4 9/4

6 9/16 3/8 3/4 9/16 3/8 3/4 9/4

7 9/16 3/8 3/4 9/16 3/8 3/4 9/4

19 ♩ = 144

1 4/4 4/4 4/4 4/4 4/4 4/4 4/4

2 4/4 4/4 4/4 4/4 4/4 4/4 4/4

3 4/4 4/4 4/4 4/4 4/4 4/4 4/4

4 4/4 4/4 4/4 4/4 4/4 4/4 4/4

5 4/4 4/4 4/4 4/4 4/4 4/4 4/4

6 4/4 4/4 4/4 4/4 4/4 4/4 4/4

7 4/4 4/4 4/4 4/4 4/4 4/4 4/4

UN PUNTO SOLO M'È MAGGIOR LETARGO GIUSEPPE SCHEMBRI BONACI

It rather borders on the mystical that Samuel Beckett's dramatic sight restoration, the first epiphanic moment after his Gozo Calypso and Mellicha sojourn in Malta, materialized when he could finally see into Caravaggio's *The Beheading of Saint John* in Valletta. "Really tremendous," Beckett—staggeringly, quasi-not-believing in such recovery—wrote to Josette Hayden.¹ Caravaggio's *chiaro-scuro* opened up Beckett's blindness; the *chiaro* begins to be gravitationally engulfed by the *scuro*—a struggle between the *chiaro* and the *scuro*—the centrifugal strife of the *chiaro* resisting being sucked into the centripetal force of the dark black, making Beckett see again.

This *chiaro* return to sight confronted by the heaviness and loudness in the silence of *The Beheading* provoked Beckett's *Not I* masterpiece: "an illuminated mouth, set high in the darkness to stage left, spews out words at an astonishing pace."² Spewing out, echo-like, waves and waves of words amid seismic heartbeat pauses: silence, intervals, words, helplessness abound in Beckett's *Not I* decollation. Depth of darkness and a beam of light, jumbled words, and utterances undulate in confusion.

The female voice is intermittently confronted by a silent figure dressed in a North African djellaba. This the Irish genius dramaturge appropriated from his Tangiers to El Jadida journey, an experience of light and silence, solitary figures, and intense listening,³ which Beckett transposed into his "Beheading," enigmatically oscillating between death, love, punishment, repentance, and God's role in the birth of Logos, where Saint John the Baptist's messianic prophecy of a new humankind is exacerbated by Saint John the Evangelist's *Verbum caro factum est*.

Confronted with such Beckettian incredulous stage darkness and appropriated from the Michelangelo Merisi da Caravaggio worldview, *Love Tastes like Death* (an earlier project of mine displayed in 2007) opted, on the contrary and on purpose, for a white-on-white statement—white being engulfed by the nothingness of white—a *chiaro-chiaro* conflict with, however, the white begetting a return to the deep black in my adjoining works of metal, copper, and steel.⁴

This, together with the bozzetto for the unrealised monument for the Maltese Historian Godfrey Wettinger, provided the foundations for the conception of the steel plate for the 2022 Malta Pavilion at the 59th Venice Biennale. The Wettinger bozzetto invited a plethora of Mediterranean complexity, of words being spewed out, as done by Beckett.

1 James Knowlson, *Damned to Fame: The Life of Samuel Beckett* (London: Bloomsbury, 1996), 588, 814.

2 Knowlson, *Damned to Fame*, 588.

3 Knowlson, *Damned to Fame*, 589.

4 Exhibition curated by Keith Sciberras; see Sciberras, *Caravaggio Quote . . . Unquote*, exh. cat. (Valletta: Malta Summer Arts Festival, 2007), 54–64.

The design for the Malta Pavilion project merges a multi-tsunami of ancient and modern languages struggling through the *chiaro-scuro* tension-wave epidemic, struggling to free themselves from the womb of earth toward their much-awaited presence. Ultimately the layered flow of writing churns out lost words and texts, disgorging long-forgotten languages and meanings, thus spilling memory asunder, leading toward a calligraphic minimalism. Memory finds itself struggling against the Dantesque and Poundian *oubli*.

These three fundamentals, which form part of the dominant line of thought in the *Metal and Silence* project,⁵ structured this project within that of the Malta Pavilion: Saint John's message of a new humankind begat the need for a new language. This new language is today encapsulated within the culture of metal.

The idea is that metal—and steel in particular—has come to define the contemporary age beyond that which appears to be obvious. Kazimir Malevich, Igor Stravinsky, Sergei Prokofiev, the Bauhaus School, and many others, believed that the era of metal pushed humankind into the age of the long-awaited superhuman, a force that would lead to global and universal domination, instead of the message of love harboured by John. One can now, today, assert Malevich's dream that, indeed, humankind can halt the sun's movement—a power previously reserved solely for the Old Testament's God of vengeance.

Apart from being the metal of global industry that has shaped the world we live in, steel was vital to the development of technology, infrastructure, and military and economic strategy. It was metal that provided all the material for modern technology, from gargantuan structures to the microchip. Armaments, wars, genocides, skyscrapers, transportation, space exploration, and more evolved and defined the modern world, the historical reality of which has been determined by steel. Metal is the skeleton upon which the veins of contemporary society flow. Yet steel is a “cold” metal. Icy cold. The coldness of Dante's hell.

The twentieth century, and now the twenty-first, are the centuries of metal. The twentieth century witnessed the true coldness of steel: the gulags, the concentration camps, the weapons of war, weapons that were used to inflict and exacerbate mass atrocities. Human progress, “superhumanity,” placed society under a *scuro* veil, blind to the steel-lined partitioning dividing the I from the you, recalling us back to *Not I*.

This is precisely where the appropriation and contextualization of Caravaggio's *The Beheading of Saint John* comes into the picture for the Malta project. *The Beheading* is not just a biblical-Christian-Catholic narrative; its meaning and message transcend its theological purpose and implications. The narrative itself—viewed only as a narrative and not as part of a belief system—explores far-reaching philosophical, political, theological, and theoretical ideas, all so relevant to today's world.

⁵ Giuseppe Schembri Bonaci, *Metal and Silence: The Quest for Daringness and Authenticity in the Arts* (Valletta: Horizons, 2020).

The Beheading—as both to the painting and the event itself, either real or mythological—is not just about an execution ordered through court intrigue, a gift bestowed on Salome by King Herod. “When the daughter of Herodias came and danced, she pleased Herod and his guests, and the king said to the girl, ‘Ask me for whatever you wish, and I will give it to you.’ At once the girl hurried in to the king with the request, ‘I want you to give me right now the head of John the Baptist on a platter’”—a head that would so beautifully and enigmatically figure as a mouth in Beckett’s work.

Saint John the Baptist was a figure far more meaningful than an inconvenient “voice in the wilderness.” His voice echoing through such neglected land is a subversive one—inherently so—and is heightened by being the solitary voice in the wilderness. Solitary voices are always dangerous. This is the reason John’s beheading is also known as the beheading of the “forerunner.” In his own lifetime, he was also regarded as the harbinger of a new era, thus a danger to society. In the words of Roman historian Flavius Josephus, “Lest the great influence John had over the people might put it into his [John’s] power and inclination to raise a rebellion (for they seemed ready to do anything he should advise), [so Herod] thought it best [to put] him to death.”⁶

John heralded the coming of the Messiah, which, in Biblical terms, signifies the New Testament: the start of a new age and a new definition of humankind based on love and the promise of salvation; another form, one may say, of a utopian dream of everlasting happiness. A new society is being called forth—a new language, a new birth, requiring a new version of the ancient script.

Historically, however, the new age that began with Saint John’s death and the prophesied coming of Christ—the advent of Christianity—would essentially determine the course of human society, the whole evolution of the modern world, including progress and vast devastation, the consequence of which would be global death.

When the same narrative is approached from this new interpretive angle, a beautiful new panorama opens up, adding to all the interpretations that already exist. It expands our appreciation—in this case, of Caravaggio’s *Beheading*—precisely by denuding it, by removing Caravaggio himself from the picture, as it were, and applying the remaining components to our own, contemporary world—remaining with, thus, Beckett’s mouth and turbulent waves of words.

The ushering in of a new age always ends in tragedy that, ultimately, puts an end to the species’s heartbeat: whether it is Christianity with the Inquisition, Communism with the gulags, whether it’s Marshall McLuhan’s computerized global village or Yoneji Masuda’s Computopia with its Assange-Snowden Kafka-blackened nightmare, or Nazism with its Holocaust dream of global racial domination. No matter how utopian an ideology claims to be, the ending is always fraught with dystopic violence and brutality. Like the dominant dictatorship of steel in

6 *Jewish Antiquities*, 18, v. 2.

the twentieth and twenty-first centuries, such ideologies usher in an age of war and genocide. Therefore, if the idea is to strive toward a world in which there is more justice and peace, more distributable sustainability—and war and genocide are ultimately the antithesis of that—one answer is to give tangible form to this utopian/dystopian dichotomy: to try, Sisyphus-like, to unconceal the concealed truth. This is being done through a multi-sifting and filtering of the twenty-eight-level wave movements of words and languages contemporaneously “chanting” psalms in Mediterranean languages—a visual, multilayered cacophony that finally gives way to the heartbeat birth and evolution of a new script-in-birth, the birth of Logos from the scratched, scorched surface of the earth. Words begotten and born.

Language, in fact, is not one of the means, but the means whereby truths are concealed to be unconcealed, manifested, made open by language itself. The multicultural richness of the Mediterranean languages, in particular those ancient languages that form the Mediterranean identity, has been explored and studied for this project. These languages formed the cradle of European genetics—that is, Aramaic, Hebrew, Latin, Greek, and Arabic together with those languages that compose the Maltese linguistic structure: Italian, Arabic, and, in today’s modern liberal world, English.

An entire process started to evolve when I overlaid these many thoughts, as well as the flow of the multiple languages that envelop us, onto Caravaggio’s masterpiece. I arrived at this idea by an inquiry into the beautiful Maltese engraved stone, the Greek-Phoenician Cippi of Melqart. Today one pillar can be seen at Malta’s National Museum of Archaeology in Valletta, the other at the Louvre in Paris—a cruel separation of the earliest pillar twinning. The Cippi and the beautiful Rosetta stone together gave modernity the key to ancient languages and thus the key to primeval identity.

Words in formation, words in conception, struggling for clarity and struggling toward presence. Words and letters imbued with multiple primordial spellings and meanings assembled in rhythmic incantations: *osse, ossa, ossea*; form, *forma, μορφή*; humankind, *hominum, homine*; life, *vita, anima*; God, *Dio, Alla, Allah*—all flow and weave themselves into an incomprehensible ocean of vowels and consonants. The image is one appropriated from the journey of the sperm struggling toward fertilization. In the Malta Pavilion project, one experiences a parallel struggle—this time, however, among words, silences, letters, and pauses, in the process of giving birth to the first utterance, itself leading to its last heartbeat before the advent of nothingness.

The texts I chose were specifically selected from Ezekiel 37 and Psalm 139 for their chanting of the creation of humankind as a universal act. In the Malta Pavilion, such “chanting” is juxtaposed with Arcangelo Sassolino’s iced metal modernity, which brings into our world the fire of destruction and purgation—and juxtaposed, too, with the phenomenal silence of Brian Schembri’s musical

score, in choral symbiosis with my cardiographic affann line,⁷ reminiscent of Beckett's pauses and utterances as his latter-day decollation is confronted by the silence of the djellaba-robed figure.



7 *Affann* in Maltese signifies the last breath before death.



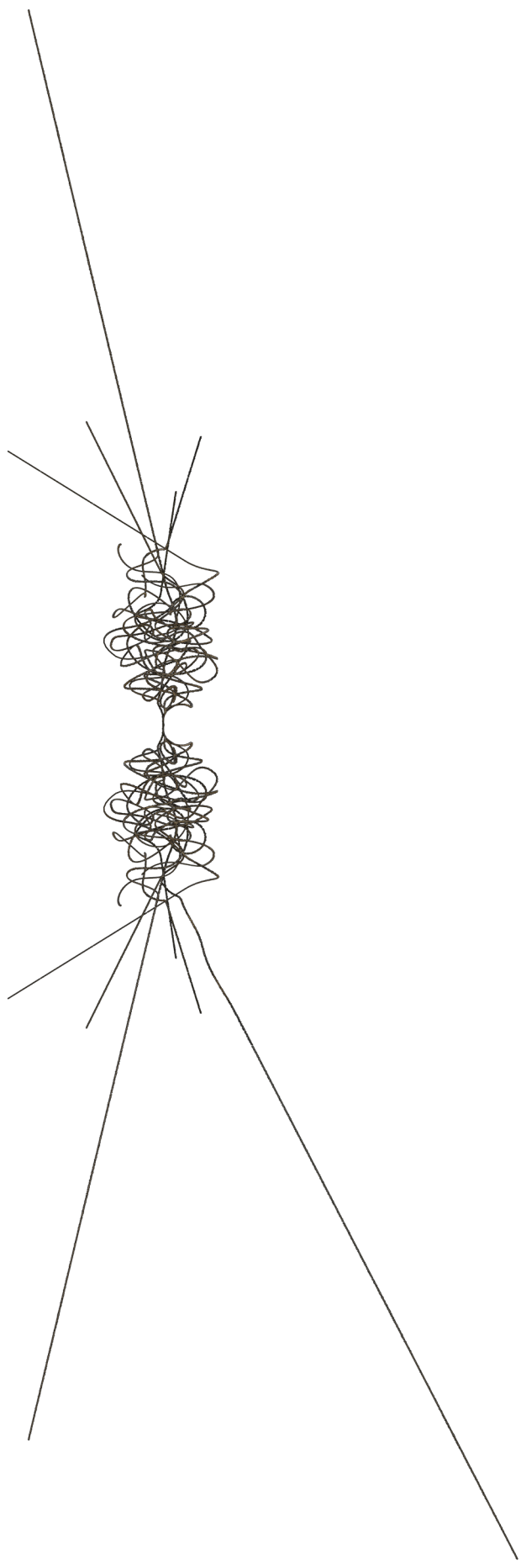



APPENDIX

BIOGRAPHIES TEAM

Professor Keith Sciberras Ph.D. is Head of the Department of Art and Art History within the Faculty of Arts, University of Malta. Received as an Andrew W. Mellon Senior Fellow (2005) in the Department of European Paintings, The Metropolitan Museum of Art, New York, in 2005, he was elected Trustee of the Association of Art Historians (AAH), London in 2012. Professor Sciberras has published extensively on the subject of Caravaggio, Roman Baroque sculpture, and Italian Baroque painting and has contributed to numerous international research projects and exhibitions.

Professor Sciberras is a Member of Senate and Rector's Delegate for the Curation of the Historic Building and Works of Art. Sciberras was this year awarded the Premio Pio Alferano 2021 for his contribution to Italian Culture.

Jeffrey Uslip is a New York-based curator who has organized exhibitions with some of the most innovative, diverse and challenging artists of our time. Uslip curated the 2017 Turner Prize nominated exhibition Hurvin Anderson: Backdrop, as solo exhibitions with Mark Bradford, Lisa Yuskavage, Joyce Pensato, Laurie Simmons and Katharina Frisch, among others. He has organized exhibitions for the Contemporary Art Museum St. Louis; Art Gallery of Ontario; the Santa Monica Museum of Art; PS1/MoMA; Artists Space; Columbia University's Graduate School of Arts and Sciences; California State University, Los Angeles; and LA><ART, Los Angeles. Additionally, he is an advanced PhD candidate at New York University's Institute of Fine Arts where he is completing his dissertation titled "Cady Noland and the Age of Reagan".

Arcangelo Sassolino was born in Vicenza in 1967 and has been exhibiting internationally since 2001, upon Luca Massimo Barbero's invitation to participate in Materia-Niente at the Fondazione Bevilacqua La Masa in Piazza San Marco in Venice as part of an exhibition that envisaged the presence of artists of the calibre of Burri, Fontana and Castellani. Solo exhibitions include the Contemporary Art Museum, St. Louis (2016); Palais de Tokyo, Paris (2008); Critical Mass, Feinkost, Berlin, Germany (2008); Galleria Continua, San Gimignano, Italy (2010); MACRO Museum, Rome, Italy (2011); the environmental projects presented in Z33 Center for Contemporary Art in Hasselt, Belgium (2010); and in the context of Art and The City in Zurich (2012). Sassolino's work has been featured in a number of group exhibitions, including shows at 104, Paris, France (2015); Bortolami Gallery, New York (2013); Centro di Cultura Contemporanea Strozziina,

Firenze, Italy (2012, 2010); Swiss Institute, New York (2011); Tinguely Museum, Basel, Switzerland (2010); Peggy Guggenheim Collection, Venice, Italy (2009); Micamoca, Berlin, Germany (2009); Dunkers Kulturhus, Helsingborg, Sweden (2008); FRAC, Rheims, France (2007); and ZKM, Karlsruhe, Germany (2004). Works by Arcangelo Sassolino can be found in public and private collections, including MART in Rovereto, 21c Museum Hotel in Louisville, Kentucky, Essl Sammlung in Vienna, UniCredit Private Banking, Fondazione Domus per l'Arte Moderna e Contemporanea and Palazzo Maffei - Fondazione Carlon, Verona.

Giuseppe Schembri Bonaci studied Philosophy, Law and the Arts. He graduated from the University of Malta, from the State University of Kiev, and from the State University of Moscow, and undertook postgraduate research studies at the State University of Milan.

He has authored several books on Modern and Contemporary Art, Philosophy of Art, and Maltese twentieth-century Art. Schembri Bonaci is coordinator of the Fine Arts Programme in the Department of Art and Art History, Artistic Director of the APS Mdina Cathedral Contemporary Art Biennale, and was Artistic Director of the Strada Stretta Concept, a cultural programme under the auspices of the Valletta Cultural Agency until 2022.

He is currently working on a series of publications on the Maltese artist Josef Kalleya's visual dialogue with Dante's *Divina Commedia* and a novel history of Mediterranean Modern Art.

Brian Schembri is one of Malta's most prolific and critically acclaimed musicians. He began his musical training at a young age under the guidance of his father Carmelo Schembri, and later graduated in piano and conducting at the Kiev and Moscow "Tchaikovsky" Conservatories. He was Chief Conductor of the OPF Orchestra and the Orquestra Metropolitana de Lisboa, Music Director at Teatru Manoel, and Artistic Director and Principal Conductor of the Malta Philharmonic Orchestra. Schembri has been awarded the Malta Cultural Award and the Medal for Service to the Republic. He has been guest conductor to the Royal Philharmonic Orchestra, Orquestra Ciutat Barcelona, Orchestre National du Capitole de Toulouse, l'Orchestre Nationale de Radio France, the Lithuanian State Symphony, Orchestre National de Lyon, London Philharmonic, Nordwestdeutsche Philharmonie, the Svetlanov State Symphony Orchestra, Hong Kong Opera, amongst others.

Nikki Petroni pursued postgraduate studies in Art History at University College London (UCL). She completed a Ph.D. in Maltese Modern

art at the University of Malta in 2019 under the supervision of Prof. Giuseppe Schembri Bonaci. Petroni is a visiting lecturer in Modern and Contemporary art at the Department of Art and Art History at the University of Malta and is the Education and Development Executive at Arts Council Malta. She is part of the curatorial committee of the APS Mdina Cathedral Contemporary Art Biennale and was Coordinator of the Strada Stretta Concept (Valletta Cultural Agency). Petroni is an independent researcher, curator, and editor of several academic essays, books, and exhibition catalogues.

Laura Dequal (Trieste, 1992) is a PhD student in Philosophy at the University of Padua, where she is working on a project about what concept of nature contemporary art presents us today. She got her MA in Philosophy at the University of Graz (Austria). Her research interests mainly concern Classical German Philosophy and Philosophy of Art.

Esther Flury is a Swiss born and NY-based arts professional with over two decades of experience working with international artists, including Paul McCarthy, Roni Horn, Berlinde de Bruyckere, Christoph Schlingensief, Mary Heilmann, Jason Rhoades and Roman Signer. Flury produced and co-curated Christoph Schlingensief's first exhibition project at the Venice Biennial: 'Church of Fear' in the Arsenale and the 'Pole Sitting Contest' in the Giardini. Initiated and managed art projects for RxArt, a nonprofit organization whose mission is to help children heal through the power of visual art by commissioning contemporary artists to transform healthcare facilities into engaging and inspiring environments. Worked as visual arts expert for the Swiss Arts Council / Pro Helvetia in the Department for Cultural Exchange with Central Eastern Europe.

Flury holds an MA in Art History, Media Sciences and Linguistics from University of Zurich, Switzerland and edited the catalogue raisonné / artist book of the work of Swiss artist Roman Signer.

BIOGRAPHIES CONTRIBUTORS

Joel Marcus is Professor Emeritus of New Testament and Christian Origins at Duke Divinity School in Durham, North Carolina USA. He is the author of a two-volume commentary on the Gospel of Mark in the Anchor Bible series published by Yale University Press and of a recent book on John the Baptist published by University of South Carolina Press.

Maria Cristina Terzaghi is Associate Professor in History of Modern Art at University of “Roma Tre” and member of the scientific committee of Museo di Capodimonte in Naples (appointed by the Italian Ministry of Fine Arts) and President of the technical and scientific committee of Fine Arts of the Italian Ministry of Cultural Heritage.